

BFI Working Paper Series  
No. 2013-005

Exploring the Nexus Between Macro-Prudential  
Policies and Monetary Policy Measures:  
Evidence from an Estimated DSGE Model for  
the Euro Area

Giacomo Carboni  
European Central Bank

Matthieu Darracq Pariès  
European Central Bank

Christoffer Kok  
European Central Bank

June 18, 2013

# Exploring the nexus between macro-prudential policies and monetary policy measures: evidence from an estimated DSGE model for the euro area\*

Giacomo Carboni<sup>†</sup>    Matthieu Darracq Pariès<sup>‡</sup>    Christoffer Kok<sup>§</sup>

June 18, 2013

## Abstract

The financial crisis highlighted the importance of systemic risks and of policies that can be employed to prevent and mitigate them. Several recent initiatives aim at establishing institutional frameworks for macro-prudential policy. As this process advances further, substantial uncertainties remain regarding the transmission channels of macro-prudential instruments as well as the interactions with other policy functions, and monetary policy in particular. This paper provides an overview and some illustrative model simulations using an estimated DSGE model for the euro area of the macroeconomic interdependence between macro-prudential instruments and monetary policy.

**Keywords:** DSGE models, Bayesian estimation, Banking, Financial regulation, macro-prudential policy, monetary policy.

**JEL classification:** E4, E5, F4.

---

\*The views expressed are solely our own and do not necessarily reflect those of the European Central Bank.

<sup>†</sup>European Central Bank.

<sup>‡</sup>European Central Bank

<sup>§</sup>European Central Bank

# 1 Introduction

A key lesson emerging from the financial crisis that erupted in 2007 was the inadequacy of the institutional policy frameworks prevailing at the time to deal with the build-up and materialisation of systemic risks. In particular, micro-prudential supervision proved to fall short by not accounting for the externalities associated with the activity of individual banks, i.e. their impact on the risk in the financial system as a whole. This led to the recognition of the importance of having macro-prudential policy arrangements in place to complement other policies, such as monetary and fiscal policy and micro-prudential supervision.

In response to these experiences, substantial efforts have been made to improve institutional arrangements for dealing with systemic risks. Macro-prudential oversight bodies have been set up in all the major economies (such as the European Systemic Risk Board in the EU, the Financial Stability Oversight Committee in the United States and the Financial Policy Committee in the United Kingdom).

Moreover, in the EU, a number of macro-prudential policy instruments are embedded in the legislative texts transposing the Basel III regulatory standards into EU law.<sup>1</sup> Furthermore, the introduction of the single supervisory mechanism (SSM) will partly lift macro-prudential policy-making to the supranational level, as the ECB-centred SSM will have the ability to implement macro-prudential measures set out in the EU legal acts (i.e. the CRD IV and the CRR).<sup>2</sup> Specifically, with the establishment of the SSM, both national competent authorities and the ECB will be the designated authorities for macro-prudential policy for the euro area as well as for countries participating in the SSM. An important element of the SSM regulation is that, if deemed necessary for addressing systemic or macro-prudential risks, the ECB will be empowered to apply higher requirements for capital buffers and other macro-prudential measures beyond those applied by authorities of participating Member States.<sup>3</sup>

The instruments contained in the EU legal texts include counter-cyclical capital buffers, systemic risk buffers, capital surcharges for systemically important financial institutions (SIFI), sectoral capital requirements/risk weights, leverage ratios, liquidity requirements and large exposure limits (see Table 1). In addition, a number of macro-prudential instruments outside the legal texts are envisaged, such as caps on loan-to-value ratios<sup>4</sup> or loan-to-income ratios, margin and haircut requirements and loan-to-deposit ratio thresholds. This broad array of macro-prudential instruments is intended to ensure that the goal of macro-prudential policy, namely of reducing systemic risk, is achieved. Systemic risk is an

---

<sup>1</sup>Namely the new Capital Requirements Directive (CRD IV) and the Capital Requirements Regulation (CRR).

<sup>2</sup>According to the SSM draft regulation. Macro-prudential measures not contained in the CRD IV and CRR will remain in the remit of national authorities.

<sup>3</sup>Importantly, the SSM legislation recognises the role of national authorities in the conduct of macro-prudential policy in the EU. Specifically, whenever appropriate or deemed necessary, and without prejudice to the tasks conferred upon the ECB, the competent or designated authorities of the participating Member States shall apply the CRD IV/CRR measures, subject to the requirement of prior notification of their intention to do so to the ECB.

<sup>4</sup>One impediment for using loan-to-value ratio caps on a euro area-wide basis is, however, the persisting differences across euro area countries with regard to the definition of these ratios and methods of collecting and aggregating relevant data. These discrepancies hamper comparison of loan-to-value ratios and could hinder macro-prudential policy coordination among the euro area countries in the future. It would accordingly be opportune to enhance efforts to harmonise statistics in this field.

elusive and multi-layered concept, which can, at a minimum, be characterised along both a time dimension and a cross-section dimension<sup>5</sup>, and hence it is generally recognised that multiple macro-prudential policy instruments may be needed to prevent the materialisation of systemic risks.

Notwithstanding these advances in the institutional set-up and the identification of relevant policy tools, substantial uncertainties surround the practical implementation of macro-prudential policies in the EU, including how to assess their potential impact on the financial system and the real economy. First of all, there is relatively limited practical experience with macro-prudential policies, at least in the major advanced economies.<sup>6</sup> Likewise, while substantial conceptual work on defining systemic risk and how to address it has taken place in recent years, a broad consensus still needs to be formed on what the specific policy objectives of the macro-prudential policy-maker should be and how it should interact with other policy functions (such as monetary policy and micro-prudential supervision). In this context, the Committee on the Global Financial System distinguishes between two main objectives of macro-prudential policies, namely to "increase the resilience of the financial sector" and to "lean against the financial cycle".<sup>7</sup>

Central in the definition of systemic risk is its pervasive nature, as well as its interaction with, and its impact on, the macroeconomic environment. Therefore, in addition to the obvious interrelation with the micro-prudential supervisory tasks of the SSM, due consideration will need to be given to how macro-prudential interventions in the euro area will interact with the conduct of monetary policy. Institutional frameworks are being established with separate decision-making, accountability and communication structures. But formidable challenges lie ahead with regard to understanding and appropriately exploiting the macroeconomic interdependence between macro-prudential and monetary policies.

Against this background, this paper first surveys the recent literature on the conduct of macro-prudential policy and, in particular, explores its nexus with monetary policy, focusing on the objective of stabilising the financial cycle. It points towards some of the challenges and issues the SSM will face once it takes on its responsibilities as a macro-prudential policy-maker.

In order to investigate the interaction between monetary and macro-prudential policies, we conduct various simulation exercises based on the estimated DSGE model of Darracq Pariès et al. [2011]. The assessment is organised around two distinct, but interrelated dimensions. First, the focus is on the transmission mechanism of individual macro-prudential instruments from a system-wide perspective. Second, the emphasis is placed on the strategic complementarities in leaning against the financial cycle as well as in exceptional crisis circumstances.

The paper is organized as follows. Section 2 summarises recent empirical evidence on the macroeconomic effects of macro-prudential instruments. Section 3 provides a short description of the DSGE

---

<sup>5</sup>For a detailed discussion about the concept of systemic risk, see Special Feature B in the December 2009 Financial Stability Review.

<sup>6</sup>Lim et al. [2011] provide an overview of lessons from country experiences with macro-prudential policies. In general, emerging market economies have made more extensive use of macro-prudential policies than advanced economies.

<sup>7</sup>See on the Global Financial System [2012].

model that subsequently is employed to analyse the various macro-prudential policy and monetary policy interactions mentioned above.<sup>8</sup> In the fourth Section we then employ the model to explore the nexus between macro-prudential policies and monetary policy measures. First, we apply the model to frame the potential strategic interactions between the monetary policy maker and the macro-prudential policy maker. Second, we use the model to simulate the macroeconomic transmission of selected macro-prudential instruments, and third we explore the implications for monetary policy in an environment where macro-prudential policies aim at leaning against the financial cycle. Section 5 concludes.

## 2 The macroeconomic effects of macro-prudential instruments: Existing evidence

Before embarking on macro-prudential interventions it will be crucial to conduct a thorough impact assessment. A useful starting point would be the stylised facts that emerge from the empirical literature on how changes in financial regulation affect banks and the wider financial and economic system. In general, policy measures affecting banks' balance sheets are likely to lead to adjustments in bank behaviour.

While there is some empirical evidence of the impact of changing capital requirements on bank loan supply and economic growth, evidence relating to the real economic impact of changes to liquidity requirements as well as asset-side regulation (such as loan-to-value ratios and loan-to-income ratios) is more limited.<sup>9</sup>

As regards the impact of changes to bank capital, a number of recent empirical studies suggest that banks typically react in a number of ways. A general finding is that banks, when faced with higher capital requirements (or capital shortfalls), are likely to adjust not only their equity levels (via retained earnings and the raising of capital), but also their lending decisions and credit conditions.<sup>10</sup> Underlying such reactions is the assumption that banks target a specific capital (or leverage) ratio and hence deviations from this target will trigger balance sheet adjustments.<sup>11</sup> Such behaviour may, however, vary across individual banks and business models, which suggests that decisions on capital-related macro-prudential interventions should take into account information about the heterogeneity of the banks affected.<sup>12</sup> Furthermore, analysing the experience with dynamic loan provisioning in Spain, Jimenez et al. [2012a] find that counter-cyclical capital buffer requirements (as reflected in the dynamic provisioning) tend to smoothen the credit cycle and can have positive real economic effects.

---

<sup>8</sup>For the purpose of brevity, many model details can be found in an appendix or especially in Darracq Pariès et al. [2010] and Darracq Pariès et al. [2011].

<sup>9</sup>For some recent reviews of the literature on the transmission of macro-prudential policies, see Fund [2013] and on the Global Financial System [2012].

<sup>10</sup>See, for example, Berrospide and Edge [2010], Francis and Osborne [2012], Maurin and Toivanen [2012] and Schepens and Kok [2012].

<sup>11</sup>See, for example, Berger et al. [2008], Flannery and Rangan [2008], and Gropp and Heider [2010].

<sup>12</sup>See, for example, Martin-Oliver et al. [2013].

These empirical findings are corroborated by results from the ECB's January 2013 bank lending survey which included responses from participating banks in the euro area on how the CRD IV and other changes in regulatory requirements had affected their balance sheets and credit standards. According to the banks' responses, these regulatory changes had induced a number of the banks to reduce their risk-weighted assets (especially related to riskier loans) and to increase nominal capital levels (via retained earnings and the raising of new capital) (see Figure 2). At the same time, a number of banks indicated that the new and more stringent regulatory requirements had contributed to the net tightening of their credit standards (and the increase in lending margins) observed over the past two years (see Figure 3). Overall, much of the available empirical evidence indicates that changes to banks' capital (and liquidity) positions, and the impact thereof on lending behaviour in particular, can potentially have considerable real economic costs, at least in the transition phase. However, these short-term costs should ideally be outweighed by the long-term benefits arising from the policy interventions in terms of reducing the probability of a crisis. Much will depend on the extent to which regulatory changes are of a transitory or permanent nature, and if the latter, the length of the transition period towards the "steady state" will play an important role.<sup>13</sup>

Turning to asset-side macro-prudential instruments, there is some (albeit limited) evidence that they can increase the resilience of banks by improving the creditworthiness of borrowers. Specifically, several studies find that tighter loan-to-value ratio caps reduce the sensitivity of households to income and property price shocks.<sup>14</sup>

Finally, Lim et al. [2011] suggest that several of the commonly used macro-prudential instruments reduce pro-cyclicality in the financial system. The analysis also suggests that the type of shocks do matter. Different types of risks call for the use of different instruments.

Apart from the empirical studies cited above, the theoretical literature on the assessment of the impact of macro-prudential policy has also been promising over the recent past, but the knowledge gap in this respect remains substantial. There is a small but resurgent body of literature on macro-prudential policy impact assessments. Some prominent early contributions identified the relevance of incorporating system-wide financial stability aspects in the overall institutional policy framework governing the monetary and financial system.<sup>15</sup> This insight was rooted in the recognition that financial systems are inherently pro-cyclical and the fact that financial cycles in general are longer than real business cycles.<sup>16</sup> Hence, there is a risk that financial developments become detached from fundamental real economic developments, which may lead to the build-up of unsustainable financial imbalances whose unravelling

---

<sup>13</sup>In this regard, two frequently cited studies are the macroeconomic assessment of the transitory costs during the implementation phase of the Basel III framework carried out by the Macroeconomic Assessment Group of the Financial Stability Board and the Basel Committee on Banking Supervision and the Basel Committee on Banking Supervision's long-term economic impact study weighing the long-run costs and benefits of the new capital and liquidity requirements embedded in the Basel III proposal (see on Banking Supervision [2010b] and on Banking Supervision [2010a]).

<sup>14</sup>See, for example, Wong et al. [2011].

<sup>15</sup>Crockett [2000] provided an early seminal contribution. See also Borio et al. [2001] and Borio [2003].

<sup>16</sup>See, for example, Drehmann et al. [2012].

("sudden busts") could have detrimental short and long-run implications for economic growth. This, it is argued, provides a role not only for monetary policy, but also for macro-prudential policy to mitigate the risks of such divergences between the real and financial cycles.<sup>17</sup>

The pro-cyclicality of the financial system can be traced to the various distortions inherent in financial relationships stemming from the existence of asymmetric information (e.g. between banks and their borrowers), resulting in adverse selection and moral hazard problems, and limited enforcement technologies, whereby borrowing is constrained by the loss given default and leads to collateral constraints. This combination can result in distorted individual behaviour, whereby intermediaries do not internalise the impact that their default could have on the system and thus may give rise to excessive risk-taking and pro-cyclicality.<sup>18</sup> In other words, there can be an endogenous build-up of imbalances within the financial system that, in the case of an adverse event, could give rise to a systemic event.<sup>19</sup> Similarly, once built-up imbalances start to unravel and banks' balance sheets become impaired, banks and their micro-prudential supervisors may react by shrinking the assets side, but in the process may fail to internalise that this could give rise to a credit crunch and asset fire sales that are likely to further amplify the initial shock.<sup>20</sup> In the light of these insights, the role of macro-prudential policy should be to pursue a "general equilibrium" perspective and, in doing so, constrain ex ante the risk-taking incentives underlying financial relationships to reduce systemic risks over the cycle and across institutions.<sup>21</sup>

Since, as mentioned above, systemic risks can take many forms, the macro-prudential toolkit requires several policy instruments. These tools should be able to cover both the time dimension and the cross-section dimension of systemic risk. Most of the existing literature evaluating the transmission and impact of macro-prudential policies, however, tends to focus on the time dimension<sup>22</sup>, whereas studies on the cross-section dimension are much less widespread.<sup>23</sup> In particular, many studies have focused on the effectiveness of counter-cyclical macro-prudential instruments in stabilising the credit cycle, alongside and interacting with the monetary policy function.

A common thread among these recent studies, while being subject to concrete model specifications overall, seems to be that macro-prudential and monetary policies in many instances can be expected to complement and support each other (as also mentioned above). However, there is also potential for a conflict of interest, or at least trade-offs, between them, such as a monetary policy that is too loose amplifying the financial cycle or, conversely, a macro-prudential policy that is too restrictive having detrimental effects on credit provision and hence monetary policy transmission. This underlines the

---

<sup>17</sup> Arguably, however, the identification of financial cycles (and booms in particular) is inherently difficult, which in turn implies that the operationalisation of macro-prudential policies targeting financial cycle stabilisation is challenging.

<sup>18</sup> For a few recent references, see Lorenzoni [2008], Mendoza [2010], Bianchi [2010] and Adrian and Shin [2011].

<sup>19</sup> See, for example, Brunnermeier and Sannikov [2012] and Boissay et al. [2012].

<sup>20</sup> See, for example, Shleifer and Vishny [2010], Diamond and Rajan [2011] and Hanson et al. [2011].

<sup>21</sup> See also Fund [2013].

<sup>22</sup> Angelini et al. [2012b] provide a comprehensive overview of existing modelling approaches to macro-prudential policy analysis.

<sup>23</sup> A notable exception is Goodhart et al. [2007].

need to ensure an appropriate institutional framework with effective coordination mechanisms among the different policy functions, with clear delineations of responsibility.<sup>24</sup>

From a research perspective, the investigation of the strategic interaction between macro-prudential and monetary policy has predominantly been carried out using DSGE models incorporating financial frictions. A general conclusion emerging from this literature is that counter-cyclical macro-prudential tools, such as time-varying capital requirements, counter-cyclical capital buffers and caps on loan-to-value ratios, can play a useful role in dampening the volatility of business cycles and can thus potentially be welfare enhancing.<sup>25</sup> For instance, the early contribution by Angeloni and Faia [2013] finds that, in a DSGE model where banks can be subject to runs, the optimal policy mix offers some role for monetary policy to lean against asset prices or bank leverage in combination with a counter-cyclical capital buffer rule. Another early paper, which focused on housing bubbles, is Kannan et al. [2009]. However, the specific calibration (design and magnitude) of the macro-prudential rule determines its effectiveness in contributing to macroeconomic stabilisation. Angelini et al. [2012a] likewise find that the mutual interaction of monetary policy and macro-prudential policy can be beneficial, especially during times when the economy is subject to large shocks, while a lack of coordination between the two policy functions can lead to conflicts of interest. Beau et al. [2012] in turn emphasise that the extent to which monetary policy and macro-prudential oversight conflict largely depends on the nature of the underlying shocks affecting the economy at a given juncture.<sup>26</sup> Moreover, Lambertini et al. [2013] suggest that using a lean-against-the-wind monetary policy or a counter-cyclical macro-prudential policy can have different welfare implications for different economic agents (e.g. borrowers vs. lenders).

### 3 Theoretical model

For the purpose of exploring the nexus between macro-prudential and monetary policies, we employ a closed-economy DSGE model with financial frictions including a banking sector which faces monopolistic competition and is subject to capital constraints. The latter may owe both to market disciplining forces (i.e. banks operate with a capital buffer) and to regulatory capital adequacy rules (which can be either risk-insensitive or risk-sensitive). Furthermore, the presence of monopolistic competition in the banking sector gives rise to some degree of stickiness in banks' adjustment of lending and deposit rates to changes in monetary policy rates. From a theoretical viewpoint a sluggish pass-through of bank loan and deposit rates to policy rate changes is based on the notion of banks having some degree of market power, which may derive from banks being "special" in the sense of being able to reduce (by acting as

<sup>24</sup>See also Cecchetti and Kohler [2012] and Ueda and Valencia [2012].

<sup>25</sup>As current state-of-the-art DSGE models are linear in nature and typically operate with representative agents, they have difficulties encompassing the multi-dimensional and potentially non-linear nature of systemic risk. This limits the scope for carrying out welfare analysis on simulated macro-prudential policies within this model set-up.

<sup>26</sup>For a similar finding see Christensen et al. [2011].

"delegated monitors") the information gap between savers and borrowers of funds.<sup>27</sup> In general, banks' interest rate setting behavior can be expected to depend on the degree of bank competition (or market power of banks) and on factors related to the costs of financial intermediation (such as interest rate and credit risk, menu costs and other operational costs, banks' degree of risk aversion and the cost of non-deposit funding sources).<sup>28</sup> Hence, by exploiting their market power banks are able to generate profits and thus to replenish their capital buffers following shocks to their liquidity and capital positions.<sup>29</sup> Under risk-sensitive capital requirements banks' capital positions are affected by changes in the risk profile of their borrowers over the business cycle and the time-varying nature of bank borrower risk profiles is therefore also considered in our modeling of firms and households.

On the real side of the economy we assume that households and firms are financially constrained in their spending and investment decisions and we furthermore incorporate some degree of heterogeneity in the household sector. The model has a subset of firms that are financially constrained and can only borrow by using revenue and capital as collateral, and a subset of financially-constrained households that use debt collateralized by housing and part of their wage income. Both firms and households are affected by idiosyncratic shocks to their collateral values. Firms and households default on their loans when the value of their collateral is below the repayment promised to the lender. In order to keep the model tractable we follow other DSGE models of financial frictions in using differences in the level of impatience of agents to generate equilibrium borrowing and lending (e.g. Iacoviello [2005]). In equilibrium, more impatient agents (borrowers and entrepreneurs) will borrow from patient savers. Building on Iacoviello and Neri [2010], Notarpietro [2007] and Solomon [2011], we define a three-agent, two-sector economy, where the impatient agents face collateral requirements when asking for mortgages or loans. Firms produce nondurable consumption goods and residential goods. The latter serve two purposes: they can be directly consumed, thus providing utility services as any durable good, or they can be used as collateral in the credit market, to obtain extra funds for financing consumption. The role of collateral constraints in closed economies has been estimated in DSGE models by Iacoviello and Neri [2010] and Notarpietro [2007], who report the relevance of housing market shocks in shaping consumption dynamics in the US. Most existing models of household borrowing in a DSGE framework follow Iacoviello [2005] and Kiyotaki and Moore [1997] in using a hard borrowing constraint and assuming it always binds. The Kiyotaki-Moore model of credit constraints can be seen as a special case of the current model in which there is no uncertainty about the future value of the collateral when the loan is made. The assumption that the constraint always binds makes the leverage ratio in their model constant. Furthermore, they ignore any difference between borrowing rates and the risk free rate. The model proposed here can at least qualitatively match the typically observed counter-cyclical leverage

---

<sup>27</sup>see e.g. Diamond and Dybvig [1983], Diamond [1984] and Diamond and Rajan [2001].

<sup>28</sup>There is ample empirical evidence for the existence of a sluggish bank interest rate pass-through in the euro area (see e.g. Mojon [2001], De Bondt [2005], Sander and Kleimeier [2006], Kok Sørensen and Werner [2006] and Gropp et al. [2007]).

<sup>29</sup>There are a few recent studies that embed features of an incomplete bank interest rate pass-through into a DSGE model framework, see e.g. Kobayashi [2008], Agenor and Alper [2009], Hülsewig et al. [2009] and Gerali et al. [2010].

ratio of households<sup>30</sup> The assumption of an always binding borrowing constraint is questionable for large shocks that may be of particular interest to policymakers, and it may severely distort the dynamics of borrowers and the rest of the economy in those circumstances. The soft borrowing constraint in our model (with interest rates rising smoothly as a function of borrowing) will always bind as long as it can be satisfied.

The only other papers that have allowed for financing frictions affecting both households and firms are Iacoviello [2005] and Gerali et al. [2010]. Both of these papers rely on hard borrowing constraints, as in Kiyotaki and Moore [1997], to model credit frictions and assume the borrowing constraints always bind. Our model setup provides an alternative perspective by including costs of default and positive lending spreads.

By allowing for frictions concerning both credit demand and supply, the contributions of this paper cover several dimensions. First, apart from encompassing the traditional financial accelerator mechanism arising in the context of financially-constrained borrowers, our model allows for assessing the impact of frictions within the banking sector, such as its price-setting behavior and constraints to its capital management. In particular, we assess the extent to which the presence of bank loan and deposit rate sluggishness affect monetary policy optimization. Moreover, our setup allows for examining the macroeconomic implications of shocks to bank capital (as those observed during the 2007-10 financial crisis as well as reflected in the proposal to introduce stronger capital requirements under the Basel III agreement) and the implications of introducing risk-sensitive capital requirements or the transitional effects of higher capital requirements. Furthermore, our model can also shed some light on the potential effects of active macro-prudential policies over the cycle and their interaction with monetary policy.

At the same time, our current model setup is less suited for analyzing the issues of liquidity and wholesale funding vulnerabilities, which arguably were other main contributing factors to the severity and propagation of the financial crisis. The macroeconomic implications of money market disruptions and the potential role of unconventional monetary policies have been addressed in other recent papers (see e.g. Gertler and Kiyotaki [2009] and also Christiano et al. [2010])

More details about the model are provided in the Appendix. A full description of the model and its estimation can be found in Darracq Pariès et al. [2010] and Darracq Pariès et al. [2011].

## **4 Exploring the macro-prudential policy and monetary policy interactions**

In this section we employ the DSGE modelling framework to explore different perspectives related to the macroeconomic propagation of macro-prudential policies and their interaction with monetary policy. As mentioned in the introduction, our simulations focus on the time dimension of macro-prudential

---

<sup>30</sup>For instance, as found for the US by Adrian and Shin [2009].

policies. In other words, the counter-cyclical use of macro-prudential instruments aimed at slowing or enhancing the financial (especially the credit) cycle.

#### 4.1 Accounting for counter cyclical macro-prudential policies

As a first step in analysing the interactions between monetary policy and macro-prudential policies is to analyse the strategic interactions between the two policy functions. In particular, we want to assess whether a counter-cyclical regulatory regime would support macroeconomic stabilization. Recent papers like Kannan et al. [2009] or Angeloni and Faia [2013] have investigated this issue with different formulation of the strategic interactions between monetary policy and macro-prudential policy. Here we focus on the joint determination of the two policy rules as to maximize an *ad hoc* loss function under credible commitment.

The inter-temporal quadratic loss function penalizes deviations from steady state for consumer price inflation, output growth and policy rate. Monetary policy conduct is described as an interest rate rule while macro-prudential policy is assumed to follow a capital requirement rule. Both rules feature policy inertia and respond to level and first difference of consumer inflation, de-trended output, and first difference of loans to households, loans to entrepreneurs, real housing prices and real equity prices<sup>31</sup>. We chose to limit the analysis to a stylized loss function instead of a welfare-based objective as the "reduced-form" nature of the bank capital friction considered in this paper would weakly portray the welfare trade-offs faced by macro-prudential policy in particular. Consequently, we preferred to abstract from welfare calculations and gear the policy discussion towards general macroeconomic stabilization without investigating how the micro-foundations of the model influence the policy objectives.

The loss function considered can be written as follows:

$$\mathcal{L}_t = \lambda_\pi \pi_t^2 + \lambda_z [\Delta z_t]^2 + \lambda_r r_t^2 + \lambda_{lev} [Leverage_t]^2 + \beta \mathbb{E}_t \mathcal{L}_{t+1}$$

where  $\lambda_\pi$ ,  $\lambda_z$  and  $\lambda_r$  are the coefficients weighting the respective costs of volatility in CPI inflation, changes in output and nominal interest rate. Later on, we would consider introducing a penalty for bank leverage volatility.

The weights in the loss function are selected in the following way. The monetary policy rule has the same form as the estimated one. The exogenous processes for the structural shocks are taken from the benchmark estimation. Then we search for the weighting scheme which delivers at the optimal rule, the same volatility for inflation and policy rate as under the estimated rule. The optimal weights we obtain are  $\lambda_\pi = 1$ ,  $\lambda_z = 4$  and  $\lambda_r = 0.75$ . Such a loss function constitutes an intuitive benchmark. Another possibility would have been to consider the full efficiency curve in the inflation, output growth space. But, for the sake of clarity, we kept only one specific loss function. The essence of the results presented thereafter holds for any point of this efficiency curve.

---

<sup>31</sup>real equity prices are defined as the average real price of fixed capital in the economy

A first exercise consists in optimizing the parameters of the monetary policy rule augmented with asset prices and credit variables, keeping capital requirements constant. We concentrate on the following formulation of the monetary policy rule.

$$r_t = \rho r_{t-1} + (1 - \rho) (r_\pi \pi_{t-1} + r_y y_{t-1}) + r_{\Delta\pi} \Delta\pi_t + r_{\Delta y} \Delta y_t \\ + r_{\Delta D} \Delta t_{D,t} + r_Q \Delta q_t + r_h \Delta b_{HH,t} + r_e \Delta b_{E,t}$$

We only consider financial shocks, as provided by the benchmark estimation: those disturbances relate to interest rate markups, borrowers' risk, bank capital and housing preference (also introduced its contribution to housing prices). Focusing on economic disturbances at the core of credit intermediation enables us to present more striking results on the role of credit and asset prices for monetary policy conduct in interaction with a counter-cyclical regulatory framework. As sensitivity analysis (not presented here), we verified that the findings exposed thereafter were still holding when all shocks were introduced.

Table 2 presents the macroeconomic volatilities associated with various optimized rules in the presence of financial shocks (except for the first column). In the first two columns, the monetary policy rule is specified as in the estimation and optimized under constant capital requirements. For the sake of completeness, the exercise is conducted either with financial shocks or with the overall set of economic disturbances. In both cases, the optimized monetary policy rule features a high level of interest rate inertia, a strong long-term response to inflation, stronger reaction to changes in output than in its level, and a specific role for housing prices. The restriction to financial shocks seems to increase the coefficient on housing prices and output growth but does not change qualitatively the main properties on the monetary policy rule. The macroeconomic variances generated by this monetary policy rule are taken as benchmark to normalize the moments obtained with the other policy regimes in Table 2.

In the third column, we allow for monetary policy reaction to credit and equity prices. The augmented optimal rule improves upon the previous one, reducing the loss function from 0.34 to 0.23. However, the lower volatility obtained for output growth and the interest rate is counterbalanced by a higher standard deviation for inflation. This optimal rule still displays a high degree of interest rate inertia, a strong reaction to inflation and some specific role for housing prices. But in addition, the rule include some positive response to household loans whereas the coefficients on loans to entrepreneurs and real equity prices are close to zero. Even without introducing asset prices or credit in the objective function, it turns out that the financial frictions on the household side vindicate some specific monetary policy focus on credit and asset prices.

With the augmented monetary policy rule specification, we also investigated the implications of risk-sensitive capital requirements. In this case, the optimized coefficients remain very close to the ones obtained with constant capital requirements (see column 4 in Table 2). At the margin, the monetary policy response to housing prices and household loans turns out to be stronger.

In the last two columns of Table 2, we allow for time-varying capital requirements. We assume that the target bank capital ratio follows a log-linear rule of the form

$$\begin{aligned} cap_t = & \rho^{bc} cap_{t-1} + r_y^{bc} y_t + r_{\Delta y}^{bc} \Delta y_t \\ & + r_{\Delta h}^{bc} \Delta b_{HH,t} + r_{\Delta e}^{bc} \Delta b_{E,t} + r_{TD}^{bc} \Delta t_{D,t} + r_Q^{bc} \Delta q_t \end{aligned}$$

Keeping the same loss function as in the previous experiments, the joint optimal determination of policy rules suggests that counter-cyclical regulation could provide a strong support to macroeconomic stabilization. The optimized capital requirement rule features some inertia and a very high positive response to output while the role for credit variables and asset prices seems negligible. The optimized monetary policy rule is very much affected by the introduction of counter-cyclical regulation: in particular, all coefficients on credit and asset prices become insignificant. Acting at the core of the financial system, regulatory policy seems to be relatively more effective than monetary policy in addressing destabilizing fluctuations in credit markets and intra-temporal wedges between financial costs, therefore alleviating somehow the need for monetary policy to "lean against the wind". The jointly determined policy rules deliver a superior macroeconomic outcome. The loss function gets close to zero, with output growth volatility at 16.5% of the benchmark, inflation volatility at 70% and interest rate at 30%. However, in the model, the main transmission channel of regulatory policy on the economy works through the adjustment of bank balance sheets and its impact on bank lending rates. Consequently, the macroeconomic stabilization support from the optimized capital requirement rule implies an almost fivefold increase in bank leverage volatility. Such a degree of counter-cyclical capital requirements would therefore be difficult to implement and lead to excessive volatility in bank balance sheets. As shown in the last column of Table 2, if we constrain the regulatory framework by introducing a relatively small penalty for leverage volatility in the loss function, then the optimized capital requirement rule becomes only moderately time-varying and the monetary policy rule is very similar to the one obtained under constant capital requirements.

Overall, while some counter-cyclical regulation seems suitable as far as macroeconomic stabilization is concerned, its design and magnitude should be carefully considered. To further explore this, in the following sub-sections we conduct various policy experiments.

## 4.2 The transmission mechanism of selected macro-prudential instruments

The propagation of macro-prudential instruments is likely to interact with the transmission mechanism of monetary policy decisions, not least as they both affect the behaviour of financial intermediaries.<sup>32</sup> In supporting the stability of the financial system and in seeking to dampen its pro-cyclical tendency,

---

<sup>32</sup>An important limitation regarding the analysis presented in this paper is that it focuses exclusively on the impact of monetary and macro-prudential policies on the banking sector. While in the euro area, banks are the most important part of the financial system, it is conceivable that macro-prudential policies (and monetary policy) will also affect financial intermediation of non-bank financial institutions.

macro-prudential instruments generally involve significant balance sheet adjustments within the financial sector, with effects on credit provision, asset prices and overall financing conditions for households and firms. Those factors may influence the transmission of the monetary policy stance and ultimately the outlook for price stability. Conversely, monetary policy will be relevant for macro-prudential oversight as it can affect agents' decisions on risk-taking, leverage, and composition of assets and liabilities. For instance, the risk-taking channel of monetary policy transmission underlines how protracted loose monetary conditions can foster incentives for financial institutions to take on more risk, thus encouraging leverage and paving the way to the build-up of financial imbalances.<sup>33</sup> More broadly, changes in the monetary policy stance influence borrowers' decisions on taking on debt by affecting the tightness of their borrowing constraints, via the impact on asset prices and borrowers' net worth, and hence on the cost of external financing for borrowers.

A first step in exploring the interaction between macro-prudential oversight and monetary policy is to analyse the macroeconomic propagation of selected macro-prudential instruments, namely: (i) system-wide bank capital requirements; (ii) sectoral capital requirements; and (iii) loan-to-value ratio restrictions.<sup>34</sup> Intuitively, the aim of system-wide capital requirements is to increase the resilience of the banking system as a whole by ensuring adequate buffers to cope with potential sizeable losses. Sectoral capital requirements make lending to certain classes of borrowers more costly and hence prompt banks to reduce their activity in that segment. Third, restrictions on loan-to-value ratios pertain to the assets side of the banking system, directly affecting the borrowing constraints of banks' customers, and hence make the banking system less vulnerable to borrower defaults.

In the following, a tentative illustration of the transmission mechanism associated with these three key macro-prudential tools is provided using the DSGE model described in Section 3, where monetary policy in the model is formalised in terms of an interest rate rule that prescribes a response to inflation, output growth and asset prices.

First, faced with *an increase in system-wide capital requirements* (calibrated as a 1.5 percentage point change in the capital ratio), banks react by charging higher margins on new loans and curtailing the provision of credit symmetrically to both households and non-financial corporations, albeit to different extents (see Figures 4 and 5). In addition, the resulting contraction in both investment and consumption expenditure depresses capital and house prices, which exacerbates the propagation effects through financial accelerator mechanisms (as the decline in collateral values tightens borrowing constraints). The impact on economic activity and inflation is mitigated by a significant monetary policy accommodation. Therefore, the monetary policy response may thus provide a significant shield for macroeconomic allocations, provided monetary policy has scope to accompany the bank balance sheet adjustment at times of in-

---

<sup>33</sup>See, for example, Jimenez et al. [2012b].

<sup>34</sup>In so doing, the assessment abstracts from normative considerations related to how macro-prudential (and monetary) policy should be conducted, and focuses instead on the positive perspective of the impact of changes in macro-prudential instruments and their interaction with the monetary policy stance.

creasing capital buffers. Conversely, the concomitant increase in capital requirements and the monetary policy rate can be expected to effectively curb bank lending and slow down economic activity.

Second, *an increase in sectoral capital requirements* makes the price of lending to the targeted sector relatively more expensive.<sup>35</sup> This triggers relative price and asset price adjustments together with substitution effects in bank lending, whereby loans decline in the target sector while lending to the non-target sector increases (see Figures 4 and 5). Overall, the effects on real GDP and inflation are influenced by the intensity of this substitution and the sectoral distribution of the transmission mechanism. In relative terms, capital requirements targeting non-financial corporate loans appear to have stronger multipliers on real GDP and consumer price index inflation, thereby leading to a more accommodative monetary policy. Capital requirements targeting housing loans lead to a less clear-cut macroeconomic configuration for monetary policy.

Finally, a lower cap on loan-to-value ratios on loans to households constrains the maximum loan that a bank is willing to grant against collateral.<sup>36</sup> The transmission mechanism features some similarities with the case of sectoral capital requirements on housing loans. However, the adverse impact on housing investment and then on output and inflation is more pronounced, partly mitigated by a prompt loosening of the monetary stance (see Figures 4 and 5).

Notably, the illustration of the real economic implications derived from these simulations reflects the effects of introducing each of the macro-prudential instruments in isolation, but does not account for the strategic complementarities between macro-prudential instruments and the benefits of combining them.

### **4.3 Macro-prudential interventions to lean against financial imbalances: Implications for monetary policy**

In principle, price stability and financial stability are complementary, and can be mutually reinforcing. Price stability contributes to financial stability by eliminating inflation-related distortions in financial markets, by containing the propagation of shocks via well-anchored inflation expectations, and by mitigating pro-cyclicality in the economy. Financial stability facilitates a central bank's task of maintaining price stability by containing excessive accumulation of credit, limiting unsustainable developments in asset prices, and mitigating the pro-cyclical reinforcing loop between real and financial variables. At the same time, as also underscored by the developments prior to the global financial crisis, price stability, while being a necessary precondition, is not sufficient for financial stability. Indeed, in the run-up to the crisis, excessive risk-taking and the accumulation of financial imbalances proceeded together with, and were possibly amplified by, a seemingly favourable perception of risk, contained macroeconomic

---

<sup>35</sup>The shocks to the sectoral capital requirement cases are calibrated so as to imply an increase in the lending spread for the target sector (i.e. lending rate minus the deposit rate, where the latter is the interbank rate), which is the same as the one underpinning the bank capital shock (in essence, the two sectoral capital requirement cases combined is equal to the bank capital shock).

<sup>36</sup>The loan-to-value ratio shocks for households are calibrated so as to imply the same peak impact on household loans (in the second year) as the one underpinning the corresponding sectoral capital requirements.

volatility and remarkable price stability.

The central banking community has long favoured the view that it may be ill-advised for monetary policy to mechanically counteract asset price misalignments and financial imbalances. At the same time, the depth of the current financial crisis calls into question this approach of the "benign neglect" of asset price misalignments and financial imbalances in the conduct of monetary policy. In essence, central banks should consider the possibility of responding to the financial cycle under certain circumstances, in particular if asset price movements are driven by capital flows and credit dynamics are based on unrealistic market expectations.

The ECB's monetary policy strategy has two distinctive features aimed at preventing the neglect of credit and financial imbalances in its monetary policy actions, namely its medium-term orientation and the prominent role of monetary analysis. Regarding the latter, the ECB's two-pillar strategy is a strategic device that contributes to limiting the tendency of monetary policy to be pro-cyclical in good times. By exploiting the association between asset price dynamics and monetary and credit developments, the monetary analysis indirectly incorporates asset price developments into policy conduct. By constantly monitoring developments in asset markets and cross-checking them with developments in the credit market and with the evolution of a number of liquidity indicators, the ECB can, at an early stage, contribute to limiting the potential of unreasonable expectations about asset prices developing further. As the recent crisis has illustrated, this monetary policy orientation is a necessary, but not sufficient precondition for crisis prevention.

Therefore, in principle, monetary policy could certainly complement macro-prudential oversight in limiting the build-up of financial risk, curbing risk incentives and addressing excessive credit growth and leverage. In practice, the precise interaction between the conduct of monetary and macro-prudential policy is likely to be influenced by the degree of concordance between real and financial cycles, which is ultimately related to the underlying shocks driving the economy and the specificities in the transmission mechanism. In a euro area context, another important issue relates to the role of macro-prudential policy in dealing with heterogeneity in credit (and other financial) cycles within a monetary union. For instance, a loose monetary policy in an economy with booming credit and asset markets may encourage excessive risk-taking and fuel imbalances. Against this background, macro-prudential policy may be a valuable tool for aligning incentives in a counter-cyclical direction as well as for addressing country-specific developments that the single monetary policy is not specifically geared towards.

To shed some light on these issues, counterfactual simulations are conducted for the euro area economy assuming two alternative configurations for the systematic response of the macro-prudential policy, where the latter is modelled in terms of counter-cyclical capital requirements.<sup>37</sup> Specifically, the capital

---

<sup>37</sup>Technically speaking, the counterfactual is conducted using the DSGE model of Darracq Pariès et al. [2011] described in Section 3, on the basis of the historical shocks extracted from the model estimation over the sample from the first quarter of 1980 to the second quarter of 2008. Notably, this implies that the estimation period only partially covers the period of the financial and sovereign debt crises, during which monetary policy conduct has arguably been different from "normal" times.

requirements tool is assumed to respond in one configuration to standard real economy variables (such as real GDP and inflation) and in a second configuration to financial-related variables, such as leverage and asset prices. Monetary policy is allowed to respond endogenously to economic developments by adjusting the stance. Overall, two considerations stand out. First, throughout the regular business cycle, the impact of alternative macro-prudential configurations on GDP remains contained overall, while their effects on loans are more pronounced (see Figures 6 and 7). This is particularly evident in the case where the macro-prudential tool is a response to the financial cycle during the run-up to the latest financial crisis. Second, during the first part of the financial crisis (see the shaded area in Figures 6 and 7), the type of macro-prudential response that is effective in leaning against the financial cycle implies, however, a more adverse drop in loans to non-financial corporations and hence in real GDP. Intuitively, this is due to the response of capital requirements to account for the increase in leverage and in indebtedness ratios in the first part of the crisis.

#### **4.4 The scope for macro-prudential interventions in exceptional times of crisis**

Once a credible macro-prudential framework has been developed and is understood by market participants, it may be appropriate and feasible to relax macro-prudential tools in times of financial stress. Indeed, the buffers built up during the upturns can be released to mitigate the reinforcing mechanisms at play in the downturn. At the same time, central banks have turned out to be the first line of defence against the risks of financial meltdown and the severe economic downturn experienced since 2008. While macro-prudential policy should strengthen the resilience of the financial system to economic downturns and other adverse aggregate shocks, monetary policy actions and notably non-standard measures remain very effective crisis management instruments in the context of specific disturbances affecting the functioning of the financial sector. Some research studies support this point. Applying a financial macro-econometric model for Japan, Kawata et al. [2013] find that, while macro-prudential policy is useful in reducing economic fluctuations by preventing the build-up of imbalances, it would need to be complemented by other policies to stimulate the economy during a contraction phase.

At the current juncture, riskier borrowing segments in the euro area, and notably small and medium-sized enterprises (SMEs), are most vulnerable to bank credit supply constraints and excessive risk aversion on the part of lenders. Given the importance of SMEs for the euro area economy, the deterioration of their financial health, especially in stressed euro area countries, and their difficulties in accessing external financing is of particular concern in terms of the impact on capital expenditure and broad economic prospects.

Taking a theoretical standpoint, we attempt to illustrate how macro-prudential instruments could be considered to address the risk of rationing in some borrowing segments in a situation of heightened bank risk aversion. The model simulation is calibrated based on a one percentage point increase in expected default frequencies for non-financial corporations over a three-year horizon. It assumes that

macro-prudential policy takes the form of sectoral capital requirements, while monetary policy is allowed to respond endogenously to economic developments by adjusting the stance. The macroeconomic implications of higher borrower riskiness hinge on the response of the banking system and bank lending policies.

First, higher corporate borrower riskiness is priced by banks into the lending rate on new loans. This rise in the cost of financing for firms weighs on capital expenditure by triggering an adverse real-financial feedback loop, whereby weaker investment dynamics and economic growth depress asset prices, further aggravate the financial vulnerabilities of firms, and thus lead to additional tightening of financing conditions.

Second, it is assumed that lenders also respond to temporarily higher borrower risk by durably increasing their capital buffers to cope with unexpected losses misperceived as being long-lasting. This channel is meant to capture excessive risk aversion of lenders, which in turn leads to further capital constraints and hence deleveraging pressures for banks. In a nutshell, the pro-cyclicality inherent in borrowing constraints and the excessive risk aversion on the part of banking institutions lead to adverse amplification effects above and beyond the impact of higher corporate borrower riskiness per se. It is precisely this amplification mechanism that macro-prudential policy could aim to contain.

Specifically, one may assume that the combined impact of corporate credit risk shocks and bank capital constraints on macroeconomic variables could be partly mitigated by macro-prudential intervention to relax sectoral capital requirements on non-financial corporation loans (see Figures 8 and 9). This policy response is effective in mitigating the large drop in the price of capital and thus contains the adverse reinforcing feedback loop between asset prices, tightening financing conditions and contracting corporate investments.<sup>38</sup> It should be recognised, however, that such a relaxation of macro-prudential requirements could be subject to potential conflicts of interest with micro-prudential supervisors who might have a preference for keeping solvency levels high to accommodate further shocks. Furthermore, it will be challenging to manage market expectations in an uncertain environment, and this will require a careful communication strategy.

## 5 Conclusions

Macro-prudential policy has emerged from the recent financial crisis as a new important policy function. This has been reflected in the establishment of new macro-prudential bodies in the major advanced economies and macro-prudential instruments have also been enshrined in the legislative proposals implementing the Basel III regulatory framework. Furthermore, a clear macro-prudential policy role is envisaged for the ECB via the legislation establishing the SSM.

---

<sup>38</sup>Macro-prudential policy takes the form of setting the target for bank capital ratios, adjusted over the cycle depending on a set of macroeconomic variables.

These developments notwithstanding, much work still needs to be carried out to improve our understanding of the transmission channels of macro-prudential policies, how macro-prudential policy interacts with other policy functions and its effectiveness both in terms of risk prevention and of risk absorption. This paper has attempted to shed some light on these issues. It has to be recognised, however, that macro-prudential policy-making is still in its infancy and substantial uncertainties about its functioning remain. The analysis presented here remains illustrative and subject to clear limitations. Notably, a structural interpretation of systemic risk (and in particular its cross-sectional dimension) is absent from the model.

With these uncertainties in mind, a key challenge when setting up institutional frameworks for macro-prudential policy-making will be to acquire sufficiently deep knowledge about the effectiveness and impact of alternative macro-prudential policy tools, including how they interact with other policies. Ultimately, a proper impact assessment of macro-prudential interventions is crucial for the precise design and calibration of the instruments.

Finally, a few caveats and directions for further research should be mentioned. First of all, the banking sector in our setup is of a reduced form nature and can be further improved. For example, a more complete description of the balance sheet composition of the banks taking into account issues such as liquidity, wholesale funding and trading book valuations would enhance the specification and also allow for analyzing the macroeconomic impact of money market disruptions, bank liquidity positions and unconventional monetary policies. Likewise, a more micro-founded optimization of the policy rule to study the interactions between macro-prudential and monetary policies could be pursued.

## References

- T. Adrian and H.S. Shin. Liquidity and leverage. *Journal of Financial Intermediation*, Forthcoming, 2009.
- T. Adrian and H.S. Shin. Procyclical leverage and value-at-risk. Staff Report 338, Federal Reserve Bank of New York, 2011.
- P.-R. Agenor and K. Alper. Monetary shocks and central bank liquidity with credit market imperfections. Discussion Paper 120, CGBCR, 2009.
- P. Angelini, S. Neri, and F. Panetta. Monetary and macroprudential rules. Working Papers 801, Banca d'Italia, 2012a.
- P. Angelini, S. Nicoletti-Altimari, and I. Visco. Macroprudential, microprudential and monetary policies: Conflicts, complementarities and trade-offs. Occasional Papers 140, Banca d'Italia, 2012b.
- I. Angeloni and E. Faia. A tale of two policies: Prudential regulation and monetary policy with fragile banks. *Journal of Monetary Economics*, (forthcoming), 2013.
- J. Ayuso, D. Pérez, and J. Saurina. Are capital buffers pro-cyclical? evidence from spanish panel data. *Journal of Financial Intermediation*, 13:249–264, 2004.
- D. Beau, L. Clerc, and B. Mojon. Macroprudential policy and the conduct of monetary policy. Working Papers 390, Banque de France, 2012.
- A.N. Berger, R. DeYoung, M.J. Flannery, D.K. Lee, and O. Oztekin. How do large banking organizations manage their capital ratios? *Journal of Financial Research*, 34(2), 2008.
- B.S. Bernanke, M. Gertler, and M. Gilchrist. *The Financial Accelerator in a Quantitative Business Cycle Framework*. in "Handbook of Macroeconomics", J.B. Taylor and M. Woodford, Eds. North-Holland, 1999.
- J.M. Berrospide and R.M. Edge. The effects of bank capital on lending: What do we know, and what does it mean? *International Journal of Central Banking*, 6(4):5–54, 2010.
- J. Bianchi. Credit externalities: Macroeconomic effects and policy implications. *American Economic Review*, 100(2), 2010.
- J. Bikker and P. Metzmakers. Is bank capital cyclical: A cross-country analysis. Working Paper Series 009, De Nederlandsche Bank, 2004.
- F. Boissay, F. Collard, and F. Smets. Booms and systemic banking crises. Working Paper Series 1514, European Central Bank, 2012.

- C. Borio. Towards a macroprudential framework for financial supervision. BIS Working Paper Series 128, Bank for International Settlements, 2003.
- C. Borio, C. Furfine, and P. Lowe. Procyclicality of the financial system and financial stability: Issues and policy options. BIS Working Paper Series 1, Bank for International Settlements, 2001.
- M. Brunnermeier and Y. Sannikov. A macroeconomic model with a financial sector. manuscript, Princeton University, 2012.
- G. Calvo. Staggered Prices in a Utility Maximizing Framework. *Journal of Monetary Economics*, 12:383–398, 1983.
- S.G. Cecchetti and M. Kohler. When capital adequacy and interest rate policy are substitutes (and when they are not). BIS Working Paper Series 379, Bank for International Settlements, 2012.
- I. Christensen, C. Meh, and K. Moran. Bank leverage regulation and macroeconomic dynamics. Working Paper 2011, Bank of Canada, 2011.
- L. Christiano, R. Motto, and M. Rostagno. Financial factors in economic fluctuations. Working Paper 1192, ECB, 2010.
- A. Crockett. Marrying micro- and macroprudential dimensions of financial stability. BIS Review 76/2000, Bank for International Settlements, 2000.
- M. Darracq Pariès, C. Kok Sørensen, and D. Rodriguez Palenzuela. Macroeconomic propagation under different regulatory regimes: Evidence from an estimated DSGE model for the euro area. Working Paper 1251, ECB, 2010.
- M. Darracq Pariès, C. Kok Sørensen, and D. Rodriguez Palenzuela. Macroeconomic propagation under different regulatory regimes: Evidence from an estimated DSGE model for the euro area. *International Journal of Central Banking*, 7(4):49–114, 2011.
- G.J. De Bondt. Interest rate pass-through: Empirical results for the euro area. *German Economic Review*, 6(1):37–78, 2005.
- D. Diamond. Financial intermediation and delegated monitoring. *Review of Economic Studies*, 51(3):393–414, 1984.
- D. Diamond and P. Dybvig. Bank runs, deposit insurance, and liquidity. *Journal of Political Economy*, 91(3):401–419, 1983.
- D. Diamond and R. Rajan. Liquidity risk, liquidity creation and financial fragility: A theory of banking. *Journal of Political Economy*, 109(2):287–327, 2001.

- D. Diamond and R. Rajan. Fear of fire sales, illiquidity seeking, and credit freezes. *Quarterly Journal of Economics*, 126(2):557–591, 2011.
- M. Drehmann, C. Borio, and K. Tsatsaronis. Characterising the financial cycle: Don't lose sight of the medium term! BIS Working Paper Series 380, Bank for International Settlements, 2012.
- M. Flannery and K.P. Rangan. What caused the bank capital build-up of the 1990s? *Review of Finance*, 12(2):391–429, 2008.
- W.B. Francis and M. Osborne. Capital requirements and bank behavior in the uk: Are there lessons for international capital standards? *Journal of Banking & Finance*, 36(3):803–816, 2012.
- International Monetary Fund. The interaction of monetary and macro-prudential policies: Background paper. Background paper, IMF, January 2013.
- A. Gerali, S. Neri, L. Sessa, and F.M. Signoretti. Credit and banking in a dsge model of the euro area. *Journal of Money, Credit and Banking*, 42(6):107–141, 2010.
- M. Gertler and N. Kiyotaki. Financial intermediation and credit policy in business cycle analysis. Mimeo, New York University, October 2009.
- C.A.E. Goodhart, A.K. Kashyap, D.P. Tsomocos, and A.P. Vardoulakis. Financial regulation in general equilibrium. Working Paper 17909, NBER, 2007.
- R. Gropp and F. Heider. The determinants of bank capital structure. *Review of Finance*, 14(4):587–622, 2010.
- R. Gropp, C. Kok Sørensen, and J. Lichtenberger. The dynamics of bank spreads and financial structure. Working Paper 714, European Central Bank, 2007.
- S.G. Hanson, A.N. Kashyap, and J.C. Stein. A macroprudential approach to financial regulation. *Journal of Economic Perspectives*, 25(1):3–28, 2011.
- O. Hülsewig, E. Mayer, and T. Wollmershäuser. Bank behavior, incomplete interest rate pass-through, and the cost channel of monetary policy transmission. *Economic Modelling*, 26:1310–1327, 2009.
- M. Iacoviello. House Prices, Borrowing Constraints and Monetary Policy in the Business Cycle. *American Economic Review*, 95(3):739–764, 2005.
- M. Iacoviello and S. Neri. Housing Markets Spillovers: Evidence from an Estimated DSGE Model. *American Economic Journal of Macroeconomics*, 2(2):125–64, 2010.
- G. Jimenez, S. Ongena, J.-L. Peydro, and J. Saurina. Macroprudential policy, countercyclical bank capital buffers and credit supply: Evidence from the spanish dynamic provisioning experiments. Discussion Paper 2012-011, European Banking Center, 2012a.

- G. Jimenez, S. Ongena, J.-L. Peydro, and J. Saurina. Credit supply and monetary policy: Identifying the bank balance-sheet channel with loan applications. *American Economic Review*, 102(2):1–30, 2012b.
- P. Kannan, P. Rabanal, and A. Scott. Monetary and macroprudential rules in a model with house prices. Working Paper WP/09/251, International Monetary Fund, 2009.
- H. Kawata, Y. Kurachi, K. Nakamura, and Y. Teranishi. Impact of macroprudential policy measures on economic dynamics: Simulation using a financial macro-econometric model. Working Paper 13-E-3, Bank of Japan, 2013.
- N. Kiyotaki and J. Moore. Credit Cycles. *Journal of Political Economy*, 105:211–248, 1997.
- K. Kobayashi, T. Nakajima, and M. Inaba. Collateral constraint and news-driven cycles. Discussion Paper 07013, RIETI, 2007.
- T. Kobayashi. Incomplete interest rate pass-through and optimal monetary policy. *International Journal of Central Banking*, 4(3), PAGES=77-118), 2008.
- C. Kok Sørensen and T. Werner. Bank interest rate pass-through in the euro area: A cross-country comparison. Working Paper 580, European Central Bank, 2006.
- L. Lambertini, C. Mendicino, and M.T. Punzi. Leaning against boom-bust cycles in credit and housing prices. *Journal of Economic Dynamics and Control*, forthcoming, 2013.
- C. Lim, F. Columba, A. Costa, P. Kongsamut, A. Otani, M. Saiyid, T. Wezel, and X. Wu. Macroprudential policy: What instruments and how to use them? lessons from country experiences. Working Paper WP/11/238, IMF, 2011.
- G. Lorenzoni. Inefficient credit booms. *Review of Financial Studies*, 73(3):809–833, 2008.
- R.E. Lucas. Liquidity and interest rates. *Journal of Economic Theory*, 50:237–264, 1990.
- A. Martin-Oliver, S. Ruano, and V. Salas-Fumas. Banks' equity capital frictions, capital ratios, and interest rates: Evidence from spanish banks. *International Journal of Central Banking*, 9(1):183–225, 2013.
- L. Maurin and M. Toivanen. Risk, capital buffer and bank lending: A granular approach to the adjustment of euro area banks. Working Paper 1499, European Central Bank, 2012.
- E. Mendoza. Sudden stops, financial crises, and leverage. *American Economic Review*, 100(5):1941–66, 2010.
- B. Mojon. Financial structure and the interest rate channel. *Economie et Provision*, 147(1):89–115, 2001.
- A. Notarpietro. Credit Frictions and Household Debt in the US Business Cycle: A Bayesian Approach. Working paper, Università Bocconi, 2007.

- Basel Committee on Banking Supervision. *An assessment of the long-term economic impact of the new regulatory framework*. Bank for International Settlements - Basel Committee on Banking Supervision Publications, August 2010a.
- Basel Committee on Banking Supervision. *Assessing the macroeconomic impact of the transition to stronger capital and liquidity requirements - Final report*. Bank for International Settlements - Basel Committee on Banking Supervision Publications, December 2010b.
- Committee on the Global Financial System. Operationalising the selection and application of macroprudential instruments. CGFS Papers 48, 2012.
- H. Sander and S. Kleimeier. Expected versus unexpected monetary policy impulses and interest rate pass-through in euro-zone retail banking markets. *Journal of Banking & Finance*, 30:1839–1870, 2006.
- G. Schepens and C. Kok. Bank reactions after capital shortfalls. paper presented at the eba research workshop on banks’ business models after the crisis, november 2012, ECB, 2012.
- S. Schmitt-Grohe and M. Uribe. Comparing Two Variants of Calvo-Type Wage Stickiness. Working Paper 12740, NBER, December 2006.
- S. Shi. A divisible search model of fiat money. *Econometrica*, 65(1):75–102, 1997.
- A. Shleifer and W. Vishny. Unstable banking. *Journal of Financial Intermediation*, 97(3):306–318, 2010.
- F. Smets and R. Wouters. Shocks and frictions in us business cycles: a bayesian dsge approach. *American Economic Review*, 97(3), 2007.
- B.-D. Solomon. Firm leverage, household leverage and the business cycle. Job market paper, February 2011.
- S. Stolz and M. Wedow. Banks’ regulatory capital buffer and the business cycle: Evidence for german savings and cooperative banks. Discussion Paper (Banking and Financial Studies) 07/2005, Deutsche Bundesbank, 2005.
- K. Ueda and F. Valencia. Central bank independence and macroprudential regulation. Working Paper Series 12/101, International Monetary Fund, 2012.
- E. Wong, T. Fong, K.-F. Li, and H. Choi. Loan-to-value ratio as a macroprudential tool - hong kong’s experience and cross-country evidence. Working Papers 01/2011, Hong Kong Monetary Authority, 2011.

## A Model description

The real side of the economy is modeled as a three-agent, two-sector economy, producing residential and non-residential goods. Residential goods are treated here as *durable* goods. A continuum of entrepreneurs, with unit mass, produce non-residential and residential intermediate goods under perfect competition and face financing constraints. Retailers differentiate the intermediate goods under imperfect competition and staggered price setting, while competitive distribution sectors serve final non-residential consumption as well as residential and non-residential investments. A continuum of infinitely-lived households, with unit mass, is composed of two types, differing in their relative intertemporal discount factor. A fraction  $(1 - \omega)$  of households are relatively *patient*, the remaining fraction  $\omega$  being *impatient*. Households receive utility from consuming both non-residential and residential goods, and disutility from labor. Impatient households are financially constrained. The labor market structure is characterized by homogeneous labor supply and monopolistically competitive unions which gives rise to staggered wage setting.

The banking sector collects deposit from patient households and provides funds to entrepreneurs and impatient households. Three layers of frictions affect financial intermediaries. First, wholesales banking branches face capital requirements (which can be risk-insensitive or risk-sensitive) as well as adjustment costs related to their capital structure. Second, some degree of nominal stickiness generates some imperfect pass-through of market rates to bank deposit and lending rates. Finally, due to asymmetric information and monitoring cost in the presence of idiosyncratic shocks, the credit contracts proposed to entrepreneurs and impatient households factor in external financing premia which depend indirectly on the borrower's leverage. Figure 1 provides an overview of the financial contracts linking the banking sector to the real economy.

Finally, a government sector collecting taxes and providing lump-sum fiscal transfers and a monetary authority applying a standard Taylor-rule close the model.

### A.1 Households

#### A.1.1 The saver's program

The patient agents,  $s \in [\omega, 1]$ , are characterized by a higher intertemporal discount factor than the borrowers, and thus act as net lenders in equilibrium. They own the productive capacities of the economy. Each patient agent receives instantaneous utility from the following instantaneous utility function:

$$\mathcal{W}_t^s = \mathbb{E}_t \left\{ \sum_{j \geq 0} \gamma^j \left[ \frac{1}{1-\sigma_X} (X_{t+j}^s)^{1-\sigma_X} - \frac{\varepsilon_{t+j}^L \bar{L}_{S,C}}{1+\sigma_{LC}} (N_{Ct+j}^s)^{1+\sigma_{LC}} - \frac{\varepsilon_{t+j}^L \bar{L}_{S,D}}{1+\sigma_{LD}} (N_{Dt+j}^s)^{1+\sigma_{LD}} \right] \varepsilon_{t+j}^\beta \right\}$$

Fig. 1: STRUCTURE OF THE MODEL

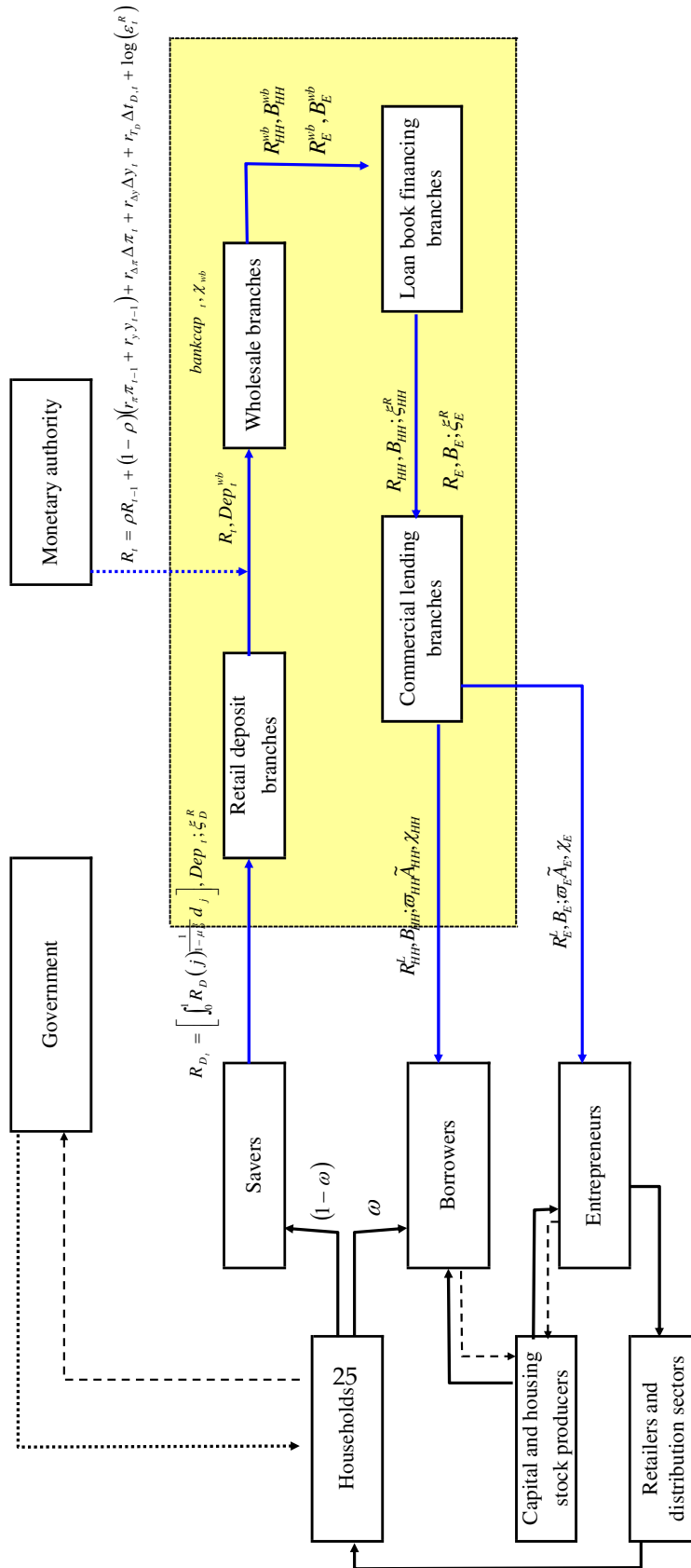

where  $X_t^s$  is an index of consumption services derived from non-residential final goods ( $C^s$ ) and residential stock ( $D^s$ ), respectively.

$$X_t^s \equiv \left[ (1 - \varepsilon_t^D \omega_D)^{\frac{1}{\eta_D}} (C_t^s - h_S C_{t-1}^s)^{\frac{\eta_D - 1}{\eta_D}} + \varepsilon_t^D \omega_D^{\frac{1}{\eta_D}} (D_t^s)^{\frac{\eta_D - 1}{\eta_D}} \right]^{\frac{\eta_D}{\eta_D - 1}}$$

with the parameter  $h_S$  capturing habit formation in consumption of non-residential goods. We introduce three stochastic terms in the utility function: a preference shock  $\varepsilon_t^\beta$ , a labor supply shock  $\varepsilon_t^L$  (common across sectors) and a housing preference shock,  $\varepsilon_t^D$ . The latter affects the relative share of residential stock,  $\omega_D$ , and modifies the marginal rate of substitution between non-residential and residential goods consumption. All the shocks are assumed to follow stationary AR(1) processes.

Households receive disutility from their supply of homogenous labor services to each sector,  $N_{C,t}^s$  and  $N_{D,t}^s$ . The real compensation of hours worked in each sector are denoted  $w_{C,t}^s$  and  $w_{D,t}^s$ . The specification of labor supply assumes that households have preferences over providing labor services across different sectors. In particular, the specific functional form adopted implies that hours worked are perfectly substitutable across sectors.  $\bar{L}_C$  and  $\bar{L}_D$  are level-shift terms needed to ensure that the patient's labor supply is equal to one in steady state.

The saver maximizes its utility function subject to an infinite sequence of the following budget constraint:

$$\begin{aligned} & C_t^s + Q_{D,t} T_{D,t} (D_t^s - (1 - \delta) D_{t-1}^s) + Dep_t^s \\ &= \frac{(1 + R_{D,t-1})}{(1 + \pi_t)} Dep_{t-1}^s + (1 - \tau_{w,t}) (w_{C,t}^s N_{C,t}^s + w_{D,t}^s N_{D,t}^s) + \Pi_t^s + TT_t^s \end{aligned}$$

where  $Q_{D,t} T_{D,t}$  is real price of housing stock in terms of non-residential goods,  $TT_t^s$  are real government transfers and  $\Pi_t^s$  are real distributed profits.  $\delta \in (0, 1)$  is the residential good depreciation rate.  $\pi_t$  is the non-residential good inflation rate.  $R_{D,t-1}$  is the nominal interest rate paid on the one-period real deposits  $Dep_t^s$ .

In equilibrium, all savers have identical consumption plans. Therefore, we can drop superscripts  $s$ . We also allow for a time-varying labor income tax, given by  $1 - \tau_{w,t} = (1 - \bar{\tau}_w) \varepsilon_t^W$ .

39

### A.1.2 The borrower's program

Each impatient agent  $b \in [0, \omega]$  receives utility from the same type of function as in the case of patient households but with a lower discount factor  $\beta < \gamma$ <sup>40</sup>:

$$\mathcal{W}_t^b = \mathbb{E}_t \left\{ \sum_{j \geq 0} \beta^j \left[ \frac{1}{1 - \sigma_X} \left( \tilde{X}_{t+j}^b \right)^{1 - \sigma_X} - \frac{\varepsilon_{t+j}^L \bar{L}_{B,C}}{1 + \sigma_{LC}} (N_{C,t+j}^b)^{1 + \sigma_{LC}} - \frac{\varepsilon_{t+j}^L \bar{L}_{B,D}}{1 + \sigma_{LD}} (N_{D,t+j}^b)^{1 + \sigma_{LD}} \right] \varepsilon_{t+j}^\beta \right\}$$

<sup>39</sup>The optimality conditions characterizing the solution of the saver's problem are reported in the Appendix.

<sup>40</sup>Variables related to the saver are denoted with a superscript  $b$ , as opposed to  $s$ , used for the savers.

where  $\tilde{X}_t^b$  is given by :

$$\tilde{X}_t^b \equiv \left[ (1 - \varepsilon_t^D \omega_D)^{\frac{1}{\eta_D}} \left( \tilde{C}_t^b - h_B \tilde{C}_{t-1}^b \right)^{\frac{\eta_D-1}{\eta_D}} + \varepsilon_t^D \omega_D^{\frac{1}{\eta_D}} \left( \tilde{D}_t^b \right)^{\frac{\eta_D-1}{\eta_D}} \right]^{\frac{\eta_D}{\eta_D-1}}$$

As regards savers,  $\bar{L}_{B,C}$  and  $\bar{L}_{B,D}$  are level-shift terms needed to ensure that the impatient's labor supply equals one in steady state.

Borrowers' incomes and housing stock values are subject to common idiosyncratic shocks  $\varpi_{HH,t}$  that are i.i.d across borrowers and across time.  $\varpi_{HH,t}$  has a lognormal CDF  $F(\varpi)$  with  $F'(\varpi) = f(\varpi)$ , and a mean of  $E(\varpi) = 1$ . The variance of the idiosyncratic shock  $\sigma_{HH,t}$  is time-varying. The value of the borrower's house is given by

$$\varpi_{HH,t} \tilde{Q}_{D,t} T_{D,t} (1 - \delta) \tilde{D}_{t-1}^b.$$

Lending in this economy is only possible through 1-period state-contingent debt contracts that require a constant repayment of  $\frac{(1+R_{HH,t}^L)}{1+\pi_t} B_{HH,t-1}$  independent of  $\varpi_{HH,t}$  if the borrower is to avoid costly loan monitoring or enforcement, where  $R_{HH,t}^L$  is the nominal lending rate.

The borrower can default and refuse to repay the debt. Savers cannot force borrowers to repay. Instead lending must be intermediated by commercial banks that have a loan enforcement technology allowing them to seize collateral expressed in real terms

$$\varpi_{HH,t} \tilde{A}_{HH,t}^b = (1 - \chi_{HH}) \varpi_{HH,t} \tilde{Q}_{D,t} T_{D,t} (1 - \delta) \tilde{D}_{t-1}^b$$

at a proportional cost  $\mu_{HH} \varpi_{HH,t} \tilde{A}_{HH,t}$  when the borrower defaults.

$\mu_{HH} \in (0, 1)$  determines the deadweight cost of default,  $0 < \chi_{HH} \leq 1$  represents housing exemptions. It defines the maximum loan to collateral ratio (often called the Loan-to-Value Ratio) that the bank is willing to grant against each component of the collateral. Conditional on enforcement, the law cannot prevent the bank from seizing  $\varpi_{HH,t} \tilde{A}_{HH,t}$ . Suppose first that the borrower does not have access to any insurance against the  $\varpi_{HH,t}$  shock. Whenever  $\varpi_{HH,t} < \bar{\varpi}_{HH,t}$  the borrower prefers to default and lose

$$\varpi_{HH,t} \tilde{A}_{HH,t}^b < \frac{(1 + R_{HH,t}^L)}{1 + \pi_t} B_{HH,t-1} = \bar{\varpi}_{HH,t} \tilde{A}_{HH,t}^b$$

when the bank enforces the contract. On the other hand when  $\varpi_{HH,t} \geq \bar{\varpi}_{HH,t}$  the borrower prefers to pay  $\frac{(1+R_{HH,t}^L)}{1+\pi_t} B_{HH,t-1}$  rather than lose  $\varpi_{HH,t} \tilde{A}_{HH,t} \geq \frac{(1+R_{HH,t}^L)}{1+\pi_t} B_{HH,t-1}$ .

To be able to use a representative agent framework while maintaining the intuition of the default rule above, we assume that borrowers belong to a large family that can pool their assets and diversify away the risk related to  $\varpi_{HH,t}$  after loan repayments are made. As in Lucas [1990] and Shi [1997], The family maximizes the expected lifetime utility of borrowers with an equal welfare weight for each borrower. The payments from the insurance scheme cannot be seized by the bank. As a result, despite the insurance the bank cannot force the borrower to repay  $\frac{(1+R_{HH,t}^L)}{1+\pi_t} B_{HH,t-1}$  when  $\varpi_{HH,t} < \bar{\varpi}_{HH,t}$ . Like the individual borrowers, the family cannot commit to always repay the loan (or make up for any lack

of payment by a borrower), even though from an ex-ante perspective it is optimal to do so. Ex-post, from the perspective of maximizing the expected welfare of the borrowers, for any given  $R_{HH,t}^L$  it is optimal to have borrowers with  $\varpi_{HH,t} < \bar{\varpi}_{HH,t}$  default and borrowers with  $\varpi_{HH,t} \geq \bar{\varpi}_{HH,t}$  repay  $\frac{(1+R_{HH,t}^L)}{1+\pi_t} B_{HH,t-1}$ .

Given the large family assumption in particular, households decisions are the same in equilibrium. Therefore, we can drop the superscript  $b$ .

By pooling the borrowers' resources, the representative family has the following aggregate repayments and defaults on its outstanding loan:

$$H(\bar{\varpi}_{HH,t})\tilde{A}_{HH,t} = [(1 - F_t(\bar{\varpi}_{HH,t}))\bar{\varpi}_{HH,t} + \int_0^{\bar{\varpi}_{HH,t}} \bar{\varpi} dF_t]\tilde{A}_{HH,t}.$$

On the commercial lending bank side, the profit made on the credit allocation is given by

$$G(\bar{\varpi}_{HH,t})\tilde{A}_{HH,t} - \frac{(1 + R_{HH,t-1})}{1 + \pi_t} B_{HH,t-1} \geq 0$$

with

$$G(\bar{\varpi}_{HH,t}) = (1 - F_t(\bar{\varpi}_{HH,t}))\bar{\varpi}_{HH,t} + (1 - \mu_{HH}) \int_0^{\bar{\varpi}_{HH,t}} \bar{\varpi} dF_t$$

$R_{HH,t-1}$  is the interest rate at which the commercial lending bank gets financing every period while  $R_{HH,t}^L$  is the state-contingent lending rate. Competition among banks will ensure that profits are null in equilibrium. The zero profit condition could also be seen as the borrowing constraint in this model. Notice that this constraint always binds as long as it can be satisfied.<sup>41</sup> In contrast, the hard borrowing constraint in Kiyotaki and Moore [1997] or Iacoviello [2005] may not bind, even though authors using that framework assume it always binds to allow the use of perturbation methods.<sup>42</sup> The caveat, is that if a new shock significantly lowers the value of  $\tilde{A}_{HH,t}$  it may be impossible to find a default threshold that allows the bank to break even on the loan with the risk free rate. This should not be a major concern except for very low aggregate shock values.<sup>43</sup>

With the assumption of perfectly competitive banks we can represent the problem of borrowers as if they choose default thresholds as a function of the aggregate states directly, subject to the bank's participation constraints.

Each borrower maximizes utility function with respect to  $(\tilde{C}_t, \tilde{D}_t, B_{HH,t}, \bar{\varpi}_{HH,t}, N_{C,t}, N_{D,t})$  subject to an infinite sequence of real budget constraints<sup>44</sup>:

$$\begin{aligned} \tilde{C}_t + \tilde{Q}_{D,t} T_{D,t} (\tilde{D}_t - (1 - \delta) \tilde{D}_{t-1}) + H(\bar{\varpi}_{HH,t}) \tilde{A}_{HH,t} &= B_{HH,t} + \tilde{T} T_t \\ &+ \tilde{w}_{C,t} \tilde{N}_{C,t} + \tilde{w}_{D,t} \tilde{N}_{D,t} \end{aligned}$$

<sup>41</sup>If the constraint were slack, the lender could always reduce the borrower's expected repayments while still respecting the constraint by reducing  $\bar{\varpi}_{HH,t}$

<sup>42</sup>This may be a reasonable assumption for small shocks, but it can be a bad approximation for larger shocks that may be of concern to policymakers.

<sup>43</sup>In our calibrations, the balanced growth path value of the Loan to Value ratio (LTV)  $G(\bar{\varpi}_{HH,t})$  is around 0.5. This suggests that we would need shocks that cause extremely large movements in the LTV on impact before we violate the upper bound on the LTV. See the appendix in Bernanke et al. [1999] for a discussion of the same issue in their model.

<sup>44</sup>We use the non-residential goods price level as a deflator.

and the zero profit condition for the commercial lending banks.<sup>45</sup>

## A.2 Labor supply and wage setting

The labor market structure is modeled following Schmitt-Grohe and Uribe [2006]. In both countries, households of each type (patient, impatient) provide homogeneous labor services, which are transformed by monopolistically competitive unions into differentiated labor inputs. As a result, all household of the same type supply the same amount of hours worked in each sector, in equilibrium.

We assume that in each sector  $j \in \{C, D\}$  there exist monopolistically competitive labor unions indexed representing the patient and impatient households. Unions differentiate the homogeneous labor provided by households,  $N_{jt}$  from savers and  $\tilde{N}_{jt}$  from borrowers, creating a continuum of measure one of labor services (indexed by  $z \in [0, 1]$ ) which are sold to labor packers.

Then perfectly competitive labor packers buy the differentiated labor input and aggregate them through a CES technology into one labor input per sector and households type. Finally the labor inputs are further combined using a Cobb-Douglas technology to produce the aggregate labor resource  $L_{C,t}$  and  $L_{D,t}$  that enter the production functions of entrepreneurs (see later). We specify the details of the labor packers profit-maximization problem below.

For  $i \in \{B, S\}$ ,  $L_{j,i,t}$  measures aggregate labor input for household type  $i$  and sector  $j$ ,

$$L_{j,i,t} = \left[ \int_0^1 L_{j,i,t}(z)^{\frac{1}{\mu_w}} dz \right]^{\mu_w}$$

while  $W_{j,i,t}$  denotes the aggregate nominal wage for type  $i$  and sector  $j$ :

$$W_{j,i,t} = \left[ \int_0^1 W_{j,i,t}(z)^{\frac{1}{1-\mu_w}} dz \right]^{1-\mu_w}$$

Each union thus faces the following labor demand (originating from sector-specific labor packers):

$$L_{j,i,t}(z) = \left( \frac{W_{j,i,t}(z)}{W_{j,i,t}} \right)^{-\frac{\mu_w}{\mu_w-1}} L_{j,i,t}$$

where  $z \in [0, 1]$ ,  $\mu_w = \frac{\theta_w}{\theta_w-1}$  and  $\theta_w > 1$  is the elasticity of substitution between differentiated labor services, which we assume to be constant across types and sectors. Clearly, our structure gives rise to four different wages in equilibrium, each corresponding to a specific worker type (patient, impatient) in a specific sector ( $C, D$ ). Unions set wages on a staggered basis. Every period, each union faces a constant probability  $1 - \alpha_{wji}$  of being able to adjust its nominal wage. If the union is not allowed to re-optimize, wages are indexed to past and steady-state inflation according to the following rule:

$$W_{j,i,t}(z) = [\Pi_{t-1}]^{\gamma_w^{j,i}} [\bar{\Pi}]^{1-\gamma_w^{j,i}} W_{j,i,t-1}(z)$$

where  $\Pi_t = \frac{P_t}{P_{t-1}}$  and  $\gamma_w^{j,i}$  denotes the degree of indexation in each sector, for each type. Taking into account that unions might not be able to choose their nominal wage optimally in the future, the optimal

<sup>45</sup>We report the first order conditions for this problem in the Appendix.

nominal wage  $\widehat{W}_{j,i,t}(z)$  is chosen to maximize intertemporal utility under the budget constraint and the labor demand function. The Appendix reports the first order conditions for this program written in a recursive form, and an expression for the aggregate wage dynamics as well as and market clearing conditions between household supply of homogenous labor services and unions differentiated labor input.

### A.3 Non-financial corporate sectors

#### A.3.1 Entrepreneurs

Entrepreneurs are also more impatient than household savers and have a discount factor  $\beta_E < \beta$ . They receive utility from their consumption of non-residential goods. They are in charge of the production of intermediate residential and non-residential goods, and operate in a perfectly competitive environment. They do not supply labor services. Their inter-temporal utility function is given by

$$\mathcal{W}_t^E = \mathbb{E}_t \left\{ \sum_{j \geq 0} (\beta_E)^j \frac{(C_{t+j}^E - h_E C_{t+j-1}^E)^{1-\sigma_{CE}}}{1-\sigma_{CE}} \varepsilon_{t+j}^\beta \right\}$$

Non-residential intermediate goods are produced with capital and labor while residential intermediate goods combine capital, labor and land. In every period of time, savers are endowed with a given amount of land, which they sell to the entrepreneurs in a fixed quantity. We assume that the supply of land is exogenously fixed and that each entrepreneur takes the price of land as given in its decision problem. Entrepreneurs make use of Cobb-Douglas technology as follows:

$$\begin{aligned} Z_t(e) &= \varepsilon_t^A (u_t^C(e) K_{t-1}^C(e))^{\alpha_C} L_t^C(e)^{1-\alpha_C} - \Omega_C \quad \forall e \in [0, 1] \\ Z_{D,t}(e) &= \varepsilon_t^{A^D} (u_t^D(e) K_{t-1}^D(e))^{\alpha_D} L_t^D(e)^{1-\alpha_D-\alpha_L} \mathcal{L}_t(e)^{\alpha_L} - \Omega_D \end{aligned}$$

where  $\varepsilon_t^A$  and  $\varepsilon_t^{A^D}$  are an exogenous technology shocks and  $\mathcal{L}_t(e)$  denotes the endowment of land used by entrepreneur  $e$  at time  $t$ . Capital is sector specific and is augmented by a variable capacity utilization rate  $u_t$ .  $MC_t$  and  $MC_{D,t}$  denote the selling prices for intermediate non-residential and residential products.

Entrepreneurs' fixed capital are subject to common multiplicative idiosyncratic shocks  $\varpi_{E,t}$ . As for households, these shocks are independent and identically distributed across time and across entrepreneurs with  $E(\varpi_{E,t}) = 1$ , and a log-normal CDF  $F^E(\varpi_{E,t})$ . Here again, the variance of the idiosyncratic shock  $\sigma_{E,t}$  is time-varying.

As for borrowers, entrepreneurs only use debt contracts in which the loan rates can be made contingent on aggregate shocks but not on the idiosyncratic shock  $\varpi_{E,t}$ . Entrepreneurs belong to a large family that can diversify the idiosyncratic risk after loan contracts are settled, but cannot commit to sharing the proceeds of this insurance with banks. Banks can seize collateral  $\varpi_{E,t} \tilde{A}_{E,t}$  when the entrepreneur

refuses to pay at a cost of  $\mu_E \bar{\omega}_{E,t} \tilde{A}_{E,t}$ . The value of the collateral that the bank can seize is

$$\bar{\omega}_{E,t} \tilde{A}_{E,t} = \bar{\omega}_{E,t} (1 - \chi_E) (1 - \delta_K) (Q_t^C K_{t-1}^C + Q_t^D K_{t-1}^D)$$

We assume that the capital utilization rate is predetermined with respect to the idiosyncratic shock to facilitate aggregation.  $\chi_E$  reflect the ability to collateralize capital This specification relates to models where only capital serves as collateral as in Gerali et al. [2010] or Kobayashi et al. [2007].

Aggregate repayments or defaults on outstanding loan to entrepreneurs are:

$$H^E(\bar{\omega}_{E,t}) \tilde{A}_{E,t} = [(1 - F_t^E(\bar{\omega}_{E,t})) \bar{\omega}_{E,t} + \int_0^{\bar{\omega}_{E,t}} \bar{\omega} dF_t^E] \tilde{A}_{E,t}.$$

On the commercial lending bank side, the profit made on the credit allocation is given by

$$G^E(\bar{\omega}_{E,t}) \tilde{A}_{E,t} - \frac{(1 + R_{E,t-1})}{1 + \pi_t} B_{E,t-1} \geq 0$$

with

$$G^E(\bar{\omega}_{E,t}) = (1 - F_t^E(\bar{\omega}_{E,t})) \bar{\omega}_{E,t} + (1 - \mu_E) \int_0^{\bar{\omega}_{E,t}} \bar{\omega} dF_t^E$$

$R_{E,t-1}$  is the interest rate at which the commercial lending bank gets financing every period while  $R_{E,t}^L$  is the state-contingent lending rate to entrepreneurs.

Overall, each entrepreneur maximizes its utility function with respect to  $(C_t^E, K_t^C, K_t^D, u_t^C, u_t^D, B_t^E, \bar{\omega}_{E,t}, L_{C,t}, L_{D,t})$  subject to an infinite sequence of real budget constraints

$$\begin{aligned} & C_t^E + Q_t^C (K_t^C - (1 - \delta_K) K_{t-1}^C) + Q_t^D (K_t^D - (1 - \delta_K) K_{t-1}^D) + H^E(\bar{\omega}_{E,t}) \tilde{A}_{E,t} \\ &= B_{E,t} + MC_{C,t} Z_t + MC_{D,t} Z_{D,t} - W_{C,t}^r L_{C,t} - W_{D,t}^r L_{D,t} - p_{lt} \mathcal{L}_t \\ & - \Phi(u_t^C) K_{t-1}^C - \Phi(u_t^D) K_{t-1}^D + TT_t^E \end{aligned}$$

together with the participation constraints for the banks. We assume the following functional form for the adjustment costs on capacity utilization:  $\Phi(X) = \frac{\bar{R}^k(1-\varphi)}{\varphi} \left( \exp \left[ \frac{\varphi}{1-\varphi} (X - 1) \right] - 1 \right)$ . Following Smets and Wouters [2007], the cost of capacity utilization is zero when capacity is fully used ( $\Phi(1) = 0$ ).  $p_{lt}$  denotes the relative price of land deflated by non-residential goods price.<sup>46</sup>

### A.3.2 Retailers and distribution sectors

Retailers differentiate the residential and non-residential goods produced by the entrepreneurs and operate under monopolistic competition. They sell their output to the perfectly competitive distribution sectors which aggregate the continuum of differentiated goods. The elementary differentiated goods are imperfect substitutes with elasticity of substitution denoted  $\frac{\mu_D}{\mu_D - 1}$  and  $\frac{\mu}{\mu - 1}$  for the residential and the non-residential sectors respectively. The distributed goods are then produced with the following technology  $Y_D = \left[ \int_0^1 Z_D(d)^{\frac{1}{\mu_D}} dd \right]^{\mu_D}$  and  $Y = \left[ \int_0^1 Z(c)^{\frac{1}{\mu}} dc \right]^{\mu}$ . The corresponding aggregate price indexes

<sup>46</sup>We report the first order conditions for this problem in the Appendix.

are defined as  $P_D = \left[ \int_0^1 p_D(d)^{\frac{1}{1-\mu_D}} dd \right]^{1-\mu_D}$  for the residential sector and  $P = \left[ \int_0^1 p(c)^{\frac{1}{1-\mu}} dc \right]^{1-\mu}$  for the non-residential sector. The distribution goods serve as final consumption goods for households and are used by capital and housing stock producers.

Retailers are monopolistic competitors which buy and the homogenous intermediate products of the entrepreneurs at prices  $MC_t$  for the non-residential intermediate goods and  $MC_{D,t}$  for the residential intermediate goods. The intermediate products are then differentiated and sold back to the distributors. Retailers set their prices on a staggered basis *à la* Calvo [1983]. In each period, a retailer in the non-residential sector faces a constant probability  $1 - \xi_C$  (resp.  $1 - \xi_D$  in the residential sector) of being able to re-optimize its nominal price. The demand curves that retailers face in each sector follow  $Z_D(d) = \left( \frac{p_D(d)}{P_D} \right)^{-\frac{\mu_D}{\mu_D-1}} Y_D$  and  $Z(c) = \left( \frac{p(c)}{P} \right)^{-\frac{\mu}{\mu-1}} Y$ .

### A.3.3 Capital and housing stock producers

Using distributed residential and non-residential goods, a segment of perfectly competitive firms, owned by the patient households, produce a stock of housing and fixed capital. At the beginning of period  $t$ , those firms buy back the depreciated housing stocks from both households types  $(1 - \delta)D_{t-1}$  and  $(1 - \delta)\tilde{D}_{t-1}$  as well as the depreciated capital stocks  $(1 - \delta_K)K_{t-1}^C$ ,  $(1 - \delta_K)K_{t-1}^D$  at real prices (in terms of consumption goods)  $Q_{D,t}T_{D,t}$ ,  $\tilde{Q}_{D,t}T_{D,t}$ ,  $Q_t^D$ ,  $Q_t^C$  respectively. Then they augment the various stocks using distributed goods and facing adjustment costs. The augmented stocks are sold back to entrepreneurs and households at the end of the period at the same prices. The decision problem of capital and housing stock producers is provided in the Appendix.

## A.4 The Banking sector

The banking sector is owned by the patient households and is segmented in three parts. Following Gerali et al. [2010], each banking group is first composed of a wholesale branch which gets financing in the money market and allocates funds to the rest of the group, facing an adjustment cost on the overall capital ratio of the group. The wholesale branch takes the bank capital and the dividend policy as given in its decision problem and operates under perfect competition. The second segment of the banking group comprises a deposit branch which collects savings from the patient households and place them in the money markets as well as two loan book financing branches which receive funding from the wholesale branch and allocate them to the commercial lending branches. In this second segment, banks operate under monopolistic competition and face nominal rigidity in their interest rate settings. The third segment of the banking group is formed by two commercial lending branches which provide loan contracts to impatient households and entrepreneurs. The commercial lending branches are zero profit competitive firms.

#### A.4.1 Wholesale branch

The perfectly competitive wholesale branches receives deposits  $Dep_t^{wb}$ , from the retail deposit banks, with an interest rate set at the policy rate  $R_t$ . Taking as given the bank capital  $Bankcap_t$  in real terms, they provide loans  $B_{E,t}^{wb}$  and  $B_{HH,t}^{wb}$  at interest rates  $R_{E,t}^{wb}$  and  $R_{HH,t}^{wb}$  to the loan book financing branches for lending to entrepreneurs and households respectively. When deciding on deposits and loans, the wholesale banks are constrained by an adjustment cost on bank's leverage. This friction is meant to capture the capital requirement pressures on the banks behavior. For this reason, we assume that wholesale banks target a capital ratio of 11% and the quadratic cost is supposed to illustrate the various interactions between banks' balance sheet structure, market disciplining forces and the regulatory framework.<sup>47</sup> On the one hand, this reflects that owing to pecuniary and reputational costs banks are keen to avoid getting too close to the regulatory minimum capital requirement and hence tend to operate with a substantial buffer over that minimum capital ratio.<sup>48</sup> On the other hand, bank capital is costly relative to other sources of financing (like deposits and bond issuance) implying that banks tend to economize on the amount of capital they hold.<sup>49</sup>

Under the Basel I-like capital requirement regime, the bank's static profit maximization problem can be formulated as follows where all quantities are expressed in real terms

$$\max_{B_{E,t}^{wb}, Dep_t^{wb}} R_{HH,t}^{wb} B_{HH,t}^{wb} + R_{E,t}^{wb} B_{E,t}^{wb} - R_t Dep_t^{wb} - \frac{\chi^{wb}}{2} \left( \frac{Bankcap_t}{0.5 B_{HH,t}^{wb} + B_{E,t}^{wb}} - 0.11 \right)^2 Bankcap_t$$

subject to the balance sheet identity

$$B_{HH,t}^{wb} + B_{E,t}^{wb} = Dep_t^{wb} + Bankcap_t$$

As in Gerali et al. (2009) the derived lending spreads emphasize "the role of bank capital in determining loan supply conditions". Hence, on the one hand, if the spread between the lending rate and the policy rate is positive, the bank would have an incentive to increase profits by raising loan volumes. This, on the other hand, would increase its leverage, which is however penalized by regulatory rules and market disciplining forces; as the capital ratio moves away from its target, which poses a cost to the bank. The bank's decision problem is therefore finely balanced between boosting its profits via increased leverage and retaining control of its capital structure. Moreover, a key point to notice for our Basel I-type specification is that the bank's target capital ratio is insensitive to changes in borrower risk over time. In addition, reflecting the risk weighting of the Basel I regulatory framework, household loans are given a (fixed) risk weight of 50% whereas the risk weight attached to corporate loans is 100%.

<sup>47</sup>The 11% capital ratio target corresponds to the average (risk-adjusted) total capital ratio of the around 100 largest euro area banks for the period 1999-2008; according to Datastream (Worldscope).

<sup>48</sup>There is a rich literature providing evidence that banks' operate with substantial capital buffers; for some recent studies see e.g. Ayuso et al. [2004], Bikker and Metzmakers [2004], Berger et al. [2008], Gropp and Heider [2010], and Stolz and Wedow [2005].

<sup>49</sup>For example, ECB estimates of the cost of equity, cost of market-based debt (i.e. bond issuance) and the cost of deposits for euro area banks show that the former was on average around 6.7% in the period 2003-2009. During the same period, banks' cost of raising debt in the capital markets was around 5%, while their average cost of deposit funding was close to 2%.

The decision problem of the wholesale bank leads to the following condition on the spread between the lending rate and the policy rate

$$\begin{aligned} R_{HH,t}^{wb} - R_t &= -\chi_{wb} \left( \frac{Bankcap_t}{0.5B_{HH,t}^{wb} + B_{E,t}^{wb}} - 0.11 \right) \left( \frac{Bankcap_t}{0.5B_{HH,t}^{wb} + B_{E,t}^{wb}} \right)^{2.5} \\ R_{E,t}^{wb} - R_t &= -\chi_{wb} \left( \frac{Bankcap_t}{0.5B_{HH,t}^{wb} + B_{E,t}^{wb}} - 0.11 \right) \left( \frac{Bankcap_t}{0.5B_{HH,t}^{wb} + B_{E,t}^{wb}} \right)^2 \end{aligned}$$

When the leverage of the bank increases beyond the targeted level, banks increase their loan-deposit margins.

The capital base of the wholesale branch is accumulated out of retained earnings from the bank group profits

$$Bankcap_t = (1 - \delta^{wb})Bankcap_{t-1} + \nu^b \Pi_t^b$$

where  $\delta^{wb}$  represents the resources used in managing bank capital,  $\Pi_t^b$  is the overall profit of the bank group and  $\nu^b$  is the share of profits not distributed to the patient households.

#### A.4.2 Imperfect pass-through of policy rate on bank lending rates

The retail deposit branch and the loan book financing branches are monopolistic competitors and set their interest rates on a staggered basis with some degree of nominal rigidity *à la Calvo*.

**Retail deposit branch** The deposits offered to patient households are a CES aggregation of the differentiated deposits provided by the retail deposit branches:  $Dep = \left[ \int_0^1 Dep(j)^{\frac{1}{\mu_D^R}} dj \right]^{\mu_D^R}$ , expressed in real terms. Retail deposits are imperfect substitute with elasticity of substitution  $\frac{\mu_D^R}{\mu_D^R - 1} < -1$ . The corresponding average interest rate offered on deposits is  $R_D = \left[ \int_0^1 R_D(j)^{\frac{1}{1-\mu_D^R}} dj \right]^{1-\mu_D^R}$ . Retail deposit branches are monopolistic competitors which collect deposit from savers and place them in the money market. Deposit branches set interest rates on a staggered basis *à la Calvo* (1983), facing each period a constant probability  $1 - \xi_D^R$  of being able to re-optimize their nominal interest rate. When a retail deposit branch cannot re-optimize its interest rate, the interest rate is left at its previous period level:

$$R_{D,t}(j) = R_{D,t-1}(j)$$

The retail deposit branch  $j$  chooses  $\hat{R}_{D,t}(j)$  to maximize its inter-temporal profit.

$$\mathbb{E}_t \left[ \sum_{k=0}^{\infty} (\gamma \xi_D^R)^k \frac{\Lambda_{t+k}}{\Lambda_t} \left( R_{t+k} Dep_{t+k}(j) - \hat{R}_{D,t}(j) Dep_{t+k}(j) \right) \right]$$

where  $Dep_{t+k}(j) = \left( \frac{\hat{R}_{D,t}(j)}{R_{D,t}} \right)^{-\frac{\mu_D^R}{\mu_D^R - 1}} \left( \frac{R_{D,t}}{R_{D,t+k}} \right)^{-\frac{\mu_D^R}{\mu_D^R - 1}} Dep_{t+k}$  and  $\Lambda_t$  is the marginal value of non-residential consumption for the households savers.

A markup shock  $\varepsilon_{D,t}^R$  is introduced on the interest rate setting.

**Loan book financing branches** As for the retail deposit branches, loan book financing branches provide funds to the commercial lending branches which obtain overall financing through a CES aggregation of the differentiated loans:  $B_{E,t} = \left[ \int_0^1 B_{E,t}(j)^{\frac{1}{\mu_E^R}} dj \right]^{\mu_E^R}$  as regards commercial loans to entrepreneurs and  $B_{HH,t} = \left[ \int_0^1 B_{HH,t}(j)^{\frac{1}{\mu_{HH}^R}} dj \right]^{\mu_{HH}^R}$  as regards commercial loans to households. Loans from loan book financing branches are imperfect substitute with elasticity of substitution  $\frac{\mu_E^R}{\mu_E^R - 1}$  and  $\frac{\mu_{HH}^R}{\mu_{HH}^R - 1} > 1$ . The corresponding average lending rate is

$$R_E = \left[ \int_0^1 R_E(j)^{\frac{1}{1-\mu_E^R}} dj \right]^{1-\mu_E^R} \text{ and } R_{HH} = \left[ \int_0^1 R_{HH}(j)^{\frac{1}{1-\mu_{HH}^R}} dj \right]^{1-\mu_{HH}^R}$$

Loan book financing branches for each segment of the credit market are monopolistic competitors which levy funds from the wholesale branches and set interest rates on a staggered basis *à la* Calvo (1983), facing each period a constant probability  $1 - \xi_E^R$  and  $1 - \xi_{HH}^R$  of being able to re-optimize their nominal interest rate. If a loan book financing branch cannot re-optimize its interest rate, the interest rate is left at its previous period level:

$$\begin{aligned} R_{HH,t}(j) &= R_{HH,t-1}(j) \\ R_{E,t}(j) &= R_{E,t-1}(j) \end{aligned}$$

In each sector  $i \in \{E, HH\}$ , the loan book financing branch  $j$  chooses  $\hat{R}_{i,t}(j)$  to maximize its intertemporal profit.

$$\mathbb{E}_t \left[ \sum_{k=0}^{\infty} (\gamma \xi_i^R)^k \frac{\Lambda_{t+k}}{\Lambda_t} \left( \hat{R}_{i,t}(j) B_{i,t+k}(j) - R_{i,t}^{wb}(j) B_{i,t+k}(j) \right) \right]$$

where  $B_{i,t+k}(j) = \left( \frac{\hat{R}_{i,t}(j)}{R_{i,t}} \right)^{-\frac{\mu_i^R}{\mu_i^R - 1}} \left( \frac{R_{i,t}}{R_{i,t+k}} \right)^{-\frac{\mu_i^R}{\mu_i^R - 1}} B_{i,t+k}$ .

As for deposit rates, we add markup shocks  $\varepsilon_{HH,t}^R$  and  $\varepsilon_{E,t}^R$  to the staggered nominal lending rate settings.

**Commercial lending branches** Commercial lending branches are delivering credit contracts for entrepreneurs and household borrowers. Those branches are perfectly competitive and in equilibrium have zero profits. Details on the credit contract and the decision problems for the commercial lending branches are provided in the sections on entrepreneurs and household borrowers.

## A.5 Government and monetary authority

Public expenditures  $\bar{G}$  are subject to random shocks  $\varepsilon_t^G$ . The government finances public spending with lump-sum transfers.

Monetary policy is specified in terms of an interest rate rule targeting inflation, output and their first difference as well as changes in the relative price of housing. Written in deviation from the steady state,

the interest rate rule used has the following form:

$$r_t = \rho r_{t-1} + (1 - \rho) (r_\pi \pi_{t-1} + r_y y_{t-1}) + r_{\Delta\pi} \Delta\pi_t + r_{\Delta y} \Delta y_t + r_{TD} \Delta t_{D,t} + \log(\varepsilon_t^R)$$

where lower case letters denote log-deviations of a variable from its deterministic steady-state.

## B Tables and charts

Tab. 1: KEY MACRO-PRUDENTIAL INSTRUMENTS

---



---

<b>CRD IV</b>
Counter-cyclical capital buffer (Art. 124)
Systemic risk buffer (Art. 124d)
SIFI capital surcharge (Art. 124a)
Sectoral capital requirements and risk weights (Art. 119)
<b>CRR</b>
Leverage ratio (as of 2019)
Liquidity Coverage Ratio (as of 2015)
Net Stable Funding Ratio (as of 2019)
Sectoral capital requirements and risk weights (Art. 160, 443)
Large exposure limits (Art. 443a)
Increased disclosure requirements (Art. 443a)
<b>outside legal texts</b>
Margin and haircut requirements
LTV ratio caps
Levy on non-stable funding
Loan-to-income ratios
Loan-to-deposit ratio caps

---



---

Tab. 2: OPTIMIZED MONETARY AND MACROPRUDENTIAL POLICY RULES

<b>Loss function</b>						
$\lambda_\pi$				1		1
$\lambda_z$				4		4
$\lambda_r$				0.75		0.75
$\lambda_{lev}$				0		0.0001
<b>Regulatory regime</b>	<i>Basel I all shocks</i>	Basel I <i>bench.</i>	Basel I	Basel II	Counter-cyclical	Counter-cyclical
<i>Optimized policy parameters</i>						
$\rho$	0.98	0.95	0.96	0.93	0.997	0.96
$r_\pi$	43.90	43.90	52.06	52.07	43.91	43.91
$r_{\Delta\pi}$	0.53	0.75	1.12	1.13	-0.43	0.43
$r_y$	0.57	0.75	0.04	0.07	0.92	0.93
$r_{\Delta y}$	0.56	1.74	2.30	2.24	1.61	1.99
$r_{TD}$	0.20	0.68	0.41	0.63	0.00	0.26
$r_{\Delta h}$	-	-	0.45	0.63	0.00	0.36
$r_Q$	-	-	0.01	0.07	0.00	0.00
$r_{\Delta e}$	-	-	-0.08	-0.12	0.00	0.02
$\rho^{bc}$	-	-	-	-	0.78	0.77
$r_y^{bc}$	-	-	-	-	113.00	0.00
$r_{\Delta y}^{bc}$	-	-	-	-	0.40	0.00
$r_{TD}^{bc}$	-	-	-	-	0.03	0.13
$r_{\Delta h}^{bc}$	-	-	-	-	-0.05	0.01
$r_Q^{bc}$	-	-	-	-	-1.91	-0.38
$r_{\Delta e}^{bc}$	-	-	-	-	-0.43	-0.11
<i>Relative STD to bench. (in %)</i>						
$\Delta Z_t$	-	100.0	80.3	102.3	16.5	78.6
$\Pi_t$	-	100.0	139.8	116.7	71.6	138.2
$R_t$	-	100.0	72.0	91.9	29.7	65.1
$T_{D,t}$	-	100.0	100.0	96.1	104.6	100.6
$B_{HH,t}$	-	100.0	97.0	84.7	227.8	103.2
$B_{E,t}$	-	100.0	99.9	80.4	136.8	94.4
$Leverage_t$	-	100.0	99.0	230.1	482.4	94.6
$\mathcal{L}$	-	0.34	0.23	0.40	0.03	0.32

Fig. 2: IMPACT OF CRD IV AND OTHER CHANGES IN REGULATORY REQUIREMENTS ON BANKS' RISK-WEIGHTED ASSETS AND CAPITAL POSITION (NET PERCENTAGE OF REPORTING BANKS)

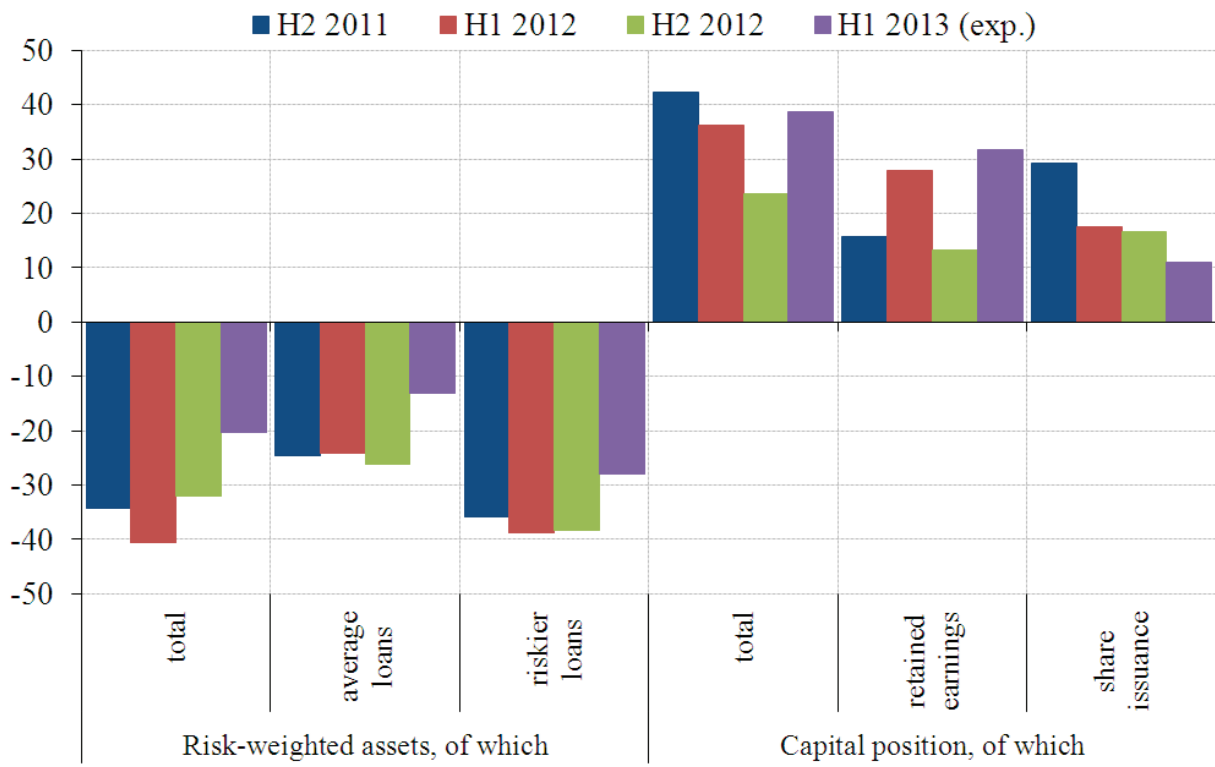

Fig. 3: CONTRIBUTION OF CRD IV AND OTHER CHANGES IN REGULATORY REQUIREMENTS TO THE TIGHTENING OF CREDIT STANDARDS (NET PERCENTAGE OF REPORTING BANKS)

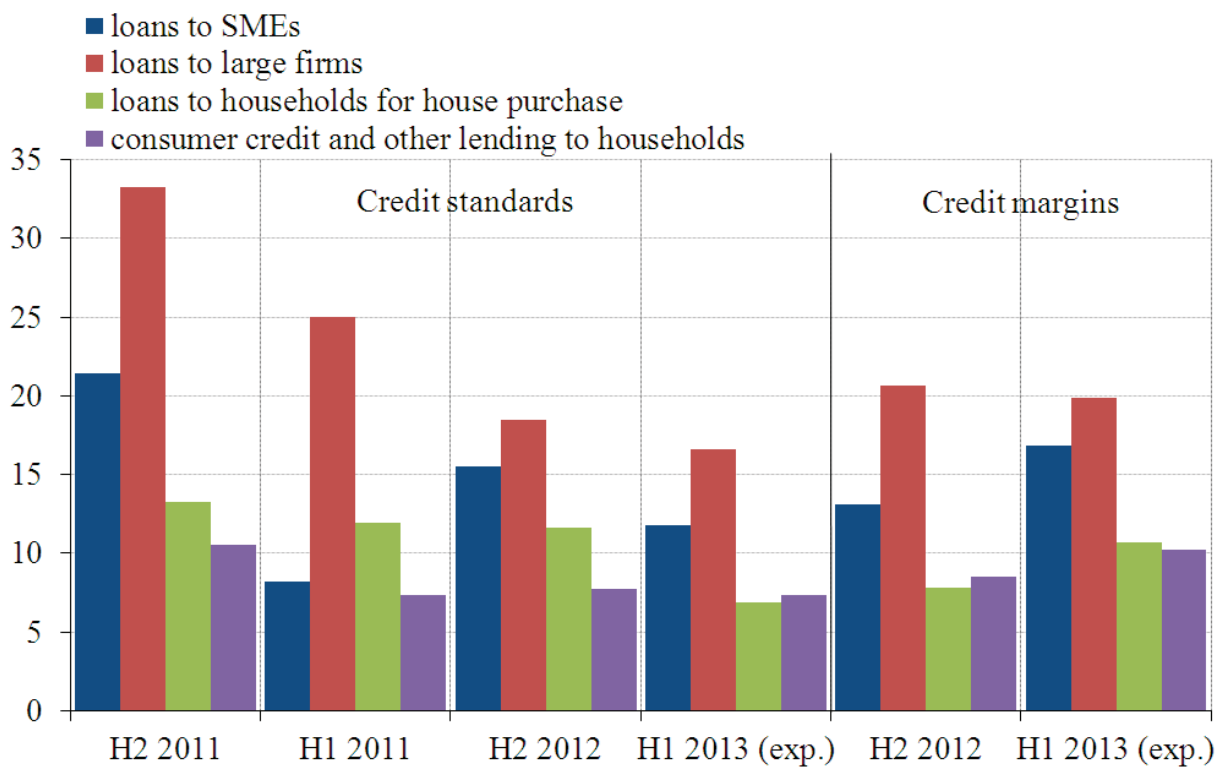

Fig. 4: TRANSMISSION MECHANISM OF SELECTED MACRO-PRUDENTIAL INSTRUMENTS UNDER ENDOGENOUS MONETARY POLICY: IMPACT ON REAL GDP, INFLATION AND THE POLICY RATE (PERCENTAGE POINT DIFFERENCE FROM BASELINE)

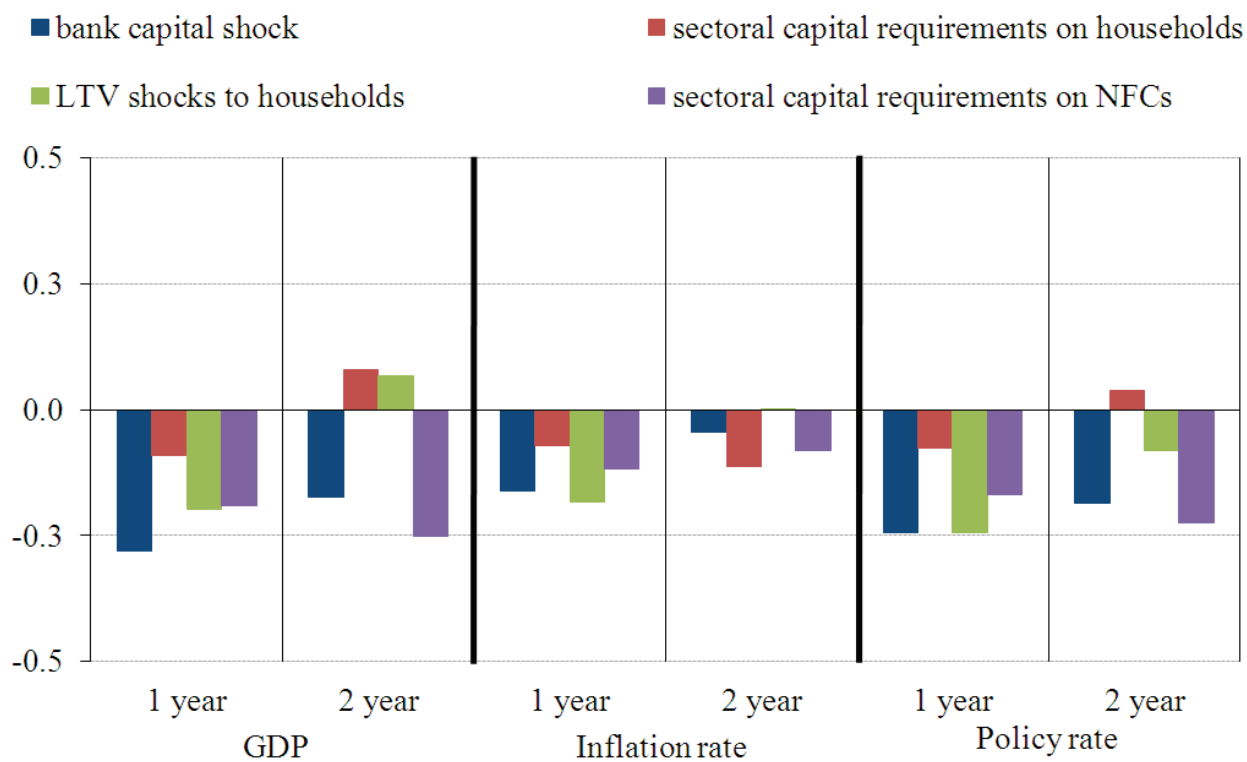

Fig. 5: TRANSMISSION MECHANISM OF SELECTED MACRO-PRUDENTIAL INSTRUMENTS UNDER ENDOGENOUS MONETARY POLICY: IMPACT ON LENDING, HOUSE PRICES AND THE PRICE OF CAPITAL (PERCENTAGE POINT DIFFERENCE FROM BASELINE)

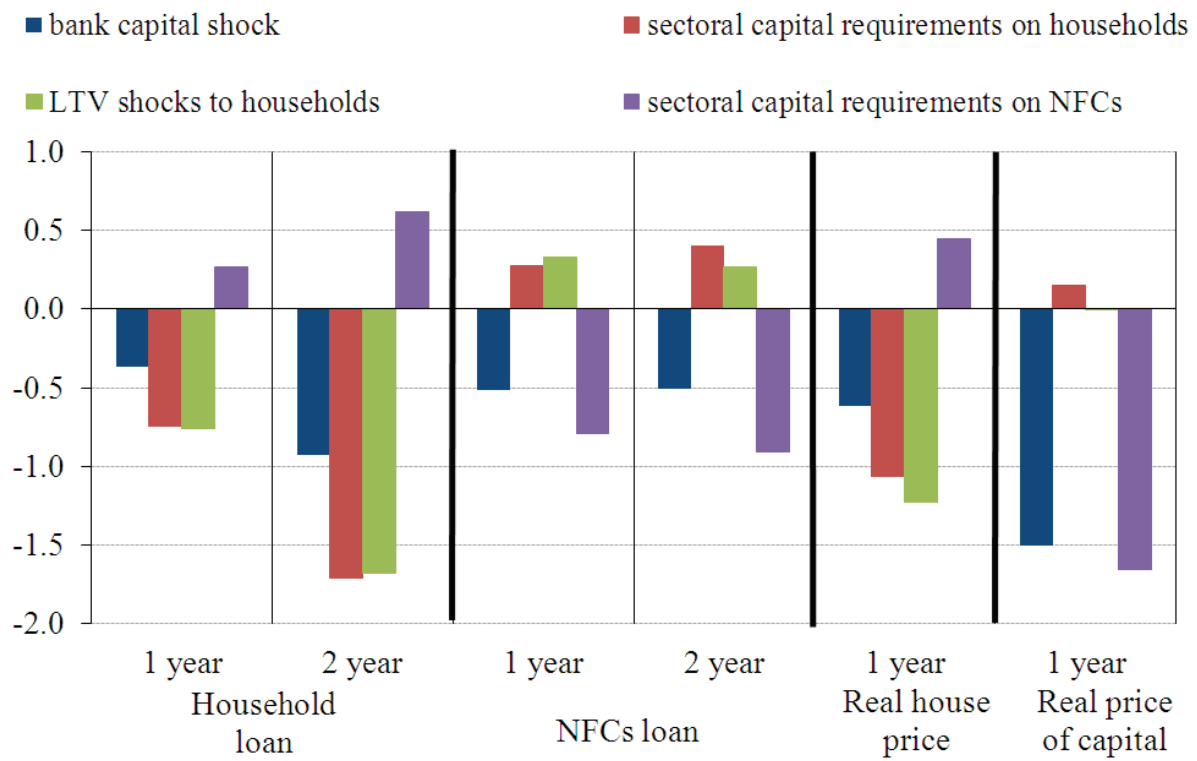

Fig. 6: MODEL COUNTERFACTUALS UNDER ALTERNATIVE SYSTEMATIC RESPONSES OF MACRO-PRUDENTIAL POLICY: A. IMPACT ON REAL GDP (PERCENTAGE POINT DIFFERENCE FROM BASELINE)

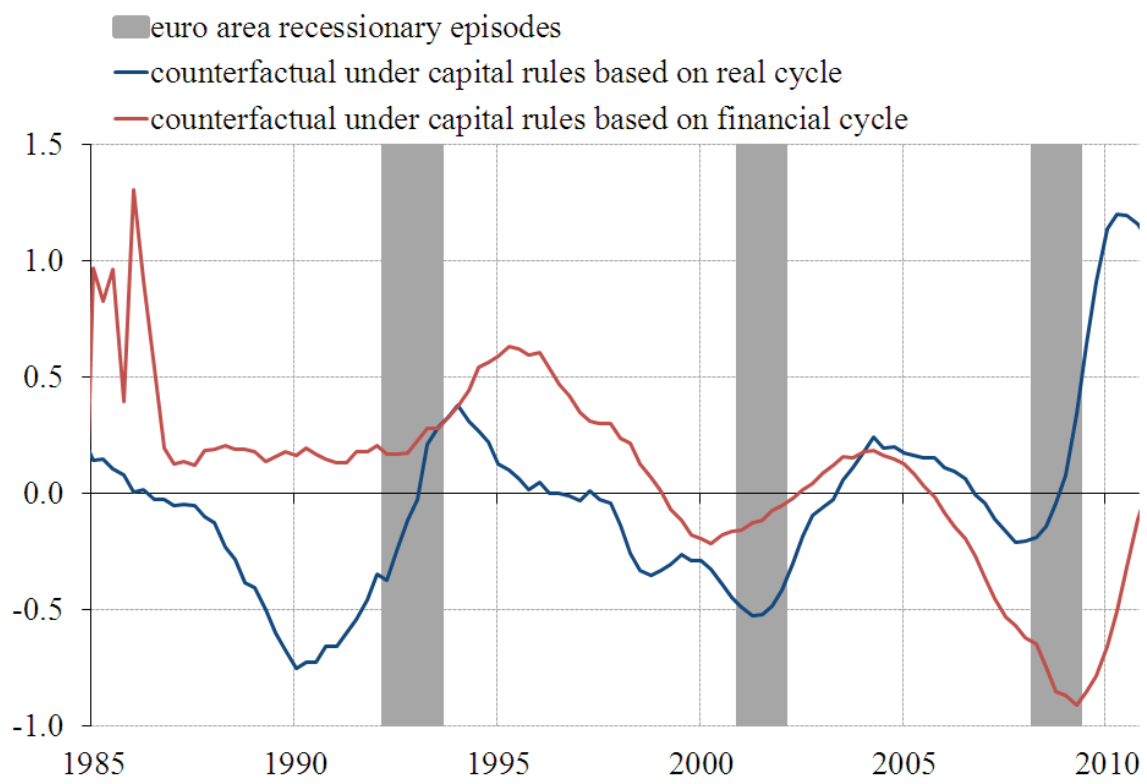

Fig. 7: MODEL COUNTERFACTUALS UNDER ALTERNATIVE SYSTEMATIC RESPONSES OF MACRO-PRUDENTIAL POLICY: A. IMPACT ON REAL BANK LOANS TO NON-FINANCIAL CORPORATIONS (PERCENTAGE POINT DIFFERENCE FROM BASELINE)

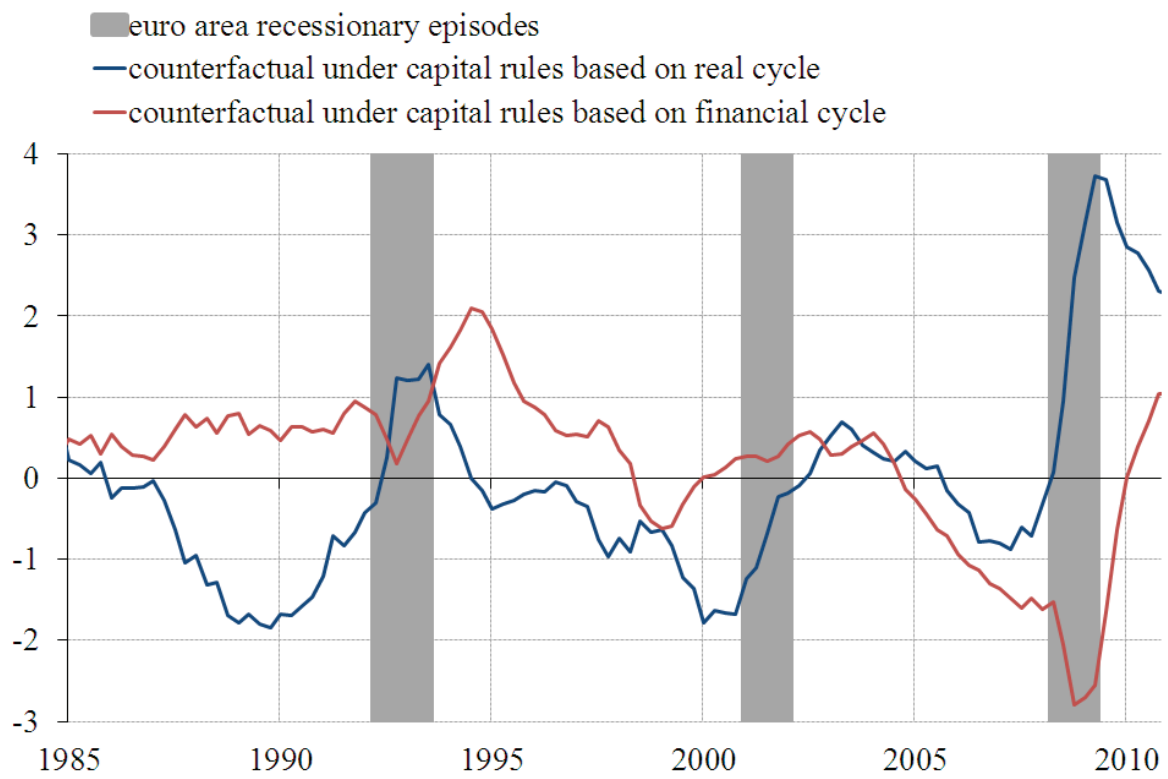

Fig. 8: MACROECONOMIC IMPLICATIONS OF CORPORATE CREDIT RISK SHOCKS: IMPACT ON REAL GDP AND INFLATION (PERCENTAGE POINT DIFFERENCE FROM BASELINE)

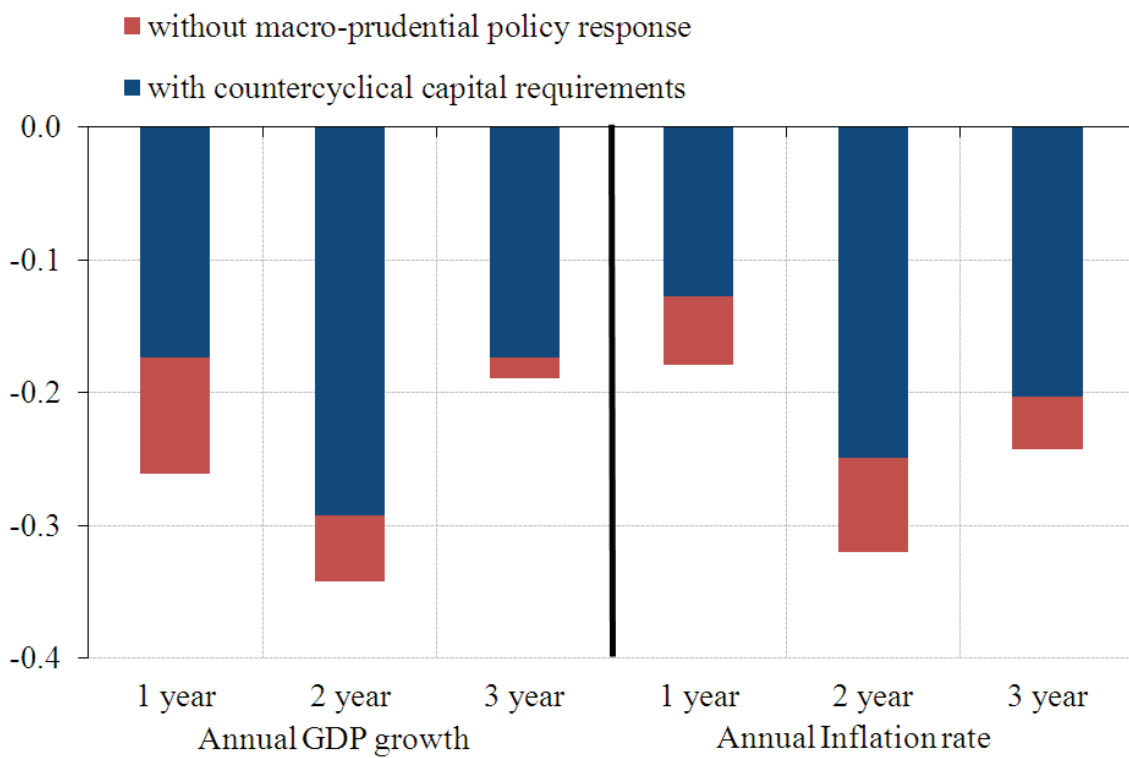

Fig. 9: MACROECONOMIC IMPLICATIONS OF CORPORATE CREDIT RISK SHOCKS: IMPACT ON ANNUAL CORPORATE LOAN GROWTH AND REAL PRICE OF CAPITAL (PERCENTAGE POINT DIFFERENCE FROM BASELINE)

